



## *Limitorque MX*

The Next Generation in Smart Multi-turn Actuation



*Experience In Motion*



## ***Flowserve Limitorque Actuation Systems***

Limitorque is an operating unit of Flowserve, a \$2+ billion-a-year company strongly focused on automation and support of the valve industry. Flowserve is the world's premier provider of flow management services.

Limitorque has evolved over 75 years since its strategic introduction of a "torque-limiting" design that changed an industry. Flowserve Limitorque offers solutions and automation choices for customers which provide:

- cost savings from field devices such as electric valve actuators.
- greater operating efficiencies from control room performance sequencing, interlocking, and continuous process optimization.
- competitive advantages derived from increased management visibility of databases and networks.

*Limitorque is one of the primary reasons Flowserve is "Experience In Motion."*





*The MX speaks your language, whether it's management, technical, financial, operations, or service.*

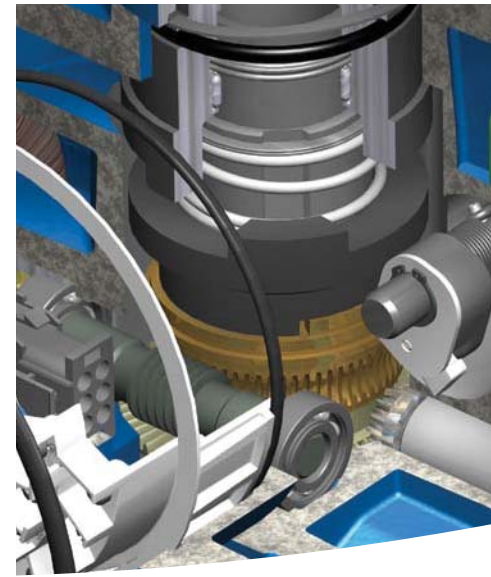
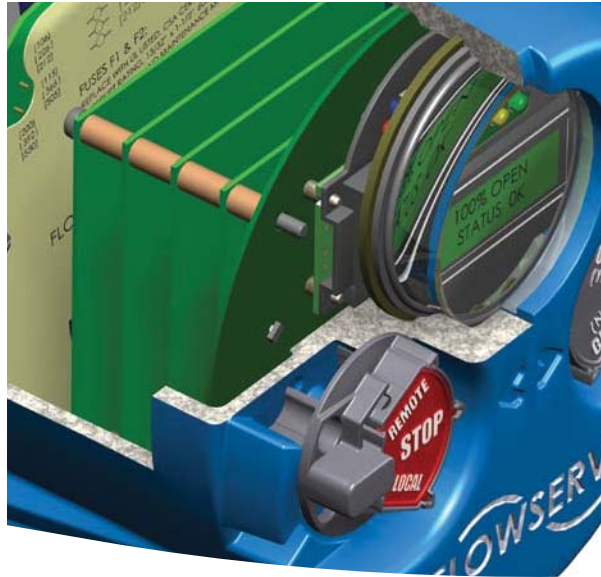

## ***MX – Still “No Batteries Required”***

*Limatorque MX: smart multi-turn actuator that delivers what you want most — control, ease of use and “no batteries required.”*

Flowserve Limatorque introduced the MX electronic actuator in 1997 as the first smart actuator that provided uncompromised reliability and performance in a design that was easy to use. The MX innovations which were market firsts – patented absolute encoder that doesn't require battery back-up – patented Limigard™ technology – easy to use menus in six languages – the use of Hall effect devices to eliminate potentially troublesome reed switches – have been improved. The features Users have come to expect from Flowserve Limatorque are still standard, but the list of improvements and optional equipment permits improved reliability, functional performance and durability. The MX is the smart actuator design that is rigorous and easy to use. It is the only non-intrusive, double-sealed electronic actuator to display the Limatorque brand.





## ***MX: The Next Generation in Smart Actuation***

### ***Speed, Precision and Simplicity***

The MX control panel features an improved 32-character LCD screen that provides actuator status and diagnostics in an easy to use, easy to read, graphical format. The industry's first multilingual actuator is now capable of configuration in English, Spanish, German, French, Italian, Portuguese, Mandarin, Russian, Bahasa Indonesia and Katakana as standard configuration languages. In addition, the LCD can be rotated 180° for better field visibility.

Speed, precision, simplicity, and set-up speed are characteristics expected of a smart actuator. Users and valve OEMs demand quick set-up and easy to understand dialog in preferred languages. The ability to either upload new software or download diagnostics is also critical to improving a plant's efficiency. The MX provides customers with the essential tools for rapid installation and root cause diagnostics.

Precision is expected in a smart actuator. The MX was the first such device developed with a patented absolute encoder that doesn't require troublesome and unpredictable battery back-up. Flowserve Litorque's innovative absolute encoder has been improved to 18-bit resolution over 10,000 drive sleeve rotations and is 100% repeatable. It now has BIST (Built In Self Test) enhancements and redundancy.

When a device is designed for BIST, its methodology is such that much of the test functionality is embedded in the device itself. BIST design facilitates a critical component's ability to communicate its actual state to a CPU for comparison to the expected state. Any deviation from expected values will be reported to the User with correlation to the failed component or sub-system.

Simplicity is expected in a smart actuator. In fact, one of the reasons for using an electronic actuator is the simplicity of set-up, installation on a valve, and acquiring diagnostic information. The MX is the simplest and easiest to use electronic actuator.





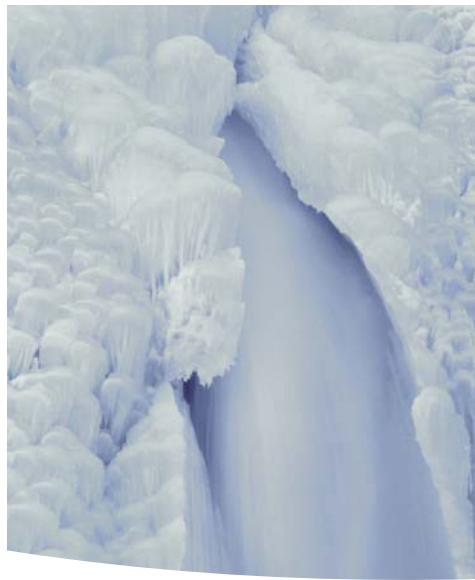

### ***Long Life and Protection***

Long life is expected in a smart actuator. There are more than 1,000,000 Limatorque actuators installed around the globe, in every conceivable environment. Many have been functioning for over 50 years. Introduced in 1997, the MX is the Flowserve Limatorque smart actuator that inherits Limatorque's legendary longevity.

In order to last a long time in severe environments smart actuators must have unparalleled protection. The MX's IP68 enclosure rating is 15M for 96 hours, regardless of whether the unit is weatherproof or explosionproof. This is an industry leading feature. Add other certifications to the list – NEMA 4, 4X, 6 – and the MX is unsurpassed in unit protection.

The MX is double-sealed, which isolates the terminal compartment from the controls environment. Any leakage into the terminal compartment is contained in the compartment.

The MX is powder coated using a polyester resin in Dupont Blue Streak color, not only for aesthetics, but also for protection in severe corrosive environments.

### ***Quality and Certifications***

Flowserve Limatorque is a global leader in quality manufacturing. All Limatorque plants are certified to ISO 9001 standards, the recognized benchmark for quality all over the world. The same unexcelled use of certified materials is found in the MX as in Limatorque's naval and nuclear qualified electric actuators. The MX has used synthetic gear oils especially optimized for use with worm gear sets since the



first unit was shipped in 1997. It was the first non-intrusive actuator to use rolled worms and electronic controls designed and produced using surface mount technology. A true globally certified device, MX meets all pertinent European Directives including ATEX, EMC, Machinery and Noise and displays the CE mark associated with such compliance.

## Anatomy of MX Multi-turn Actuators

Limatorque MX actuators respond to customer needs with advanced features designed for ease of commissioning and use, as well as time- and money-saving operational benefits. What sets the MX apart is the combination of control and reliability enabled by advanced Limatorque technology, plus superior ergonomics and human interfaces for speed, comfort, and ease of use.

*The reliable MX motor includes Class F insulation and thermal protection. It is designed specifically for valve actuator service, with a high starting torque and low inertia to reduce valve position overshoot. Class H is available as an option.*

*Motor gear attachment allows the motor to be removed in one assembly for fast, easy inspection, repair, and maintenance.*

*MX actuators feature a LimiGard™ circuit monitor that is designed for Fail/No-Action protection. LimiGard consists of dedicated circuitry that continually monitors the motor contactor, control relays, internal logic circuits, and external command signals to detect and alarm malfunctions. It now includes BIST with Frequency Domain Analysis (FDA) for true predictive maintenance.*

*Plug-in connectors permit quick and easy replacement of components.*

*Double-sealed design provides a termination chamber that is separate and sealed from the control chamber. Control components are never exposed to the elements during site wiring or because of a faulty cable connection.*

*External connection block has three power terminals, a ground screw, and 54 control screw-type terminals to simplify commissioning and upgrades.*

*Long-life gear set consists of hardened alloy steel rolled worm and bronze worm gear immersed in an extended-life synthetic gear oil specifically developed for worm gear operation. It is completely bearing-supported.*

*Ductile iron thrust base is removable from main actuator housing for easier valve installation and maintenance.*

*High-strength, bronze alloy stem nut is removable for machining to suit the valve stem.*

*The control chamber includes an electronic control, monitoring, and protection module mounted on steel plate. Plug-in connectors allow fast, error-free removal and replacement of the module.*

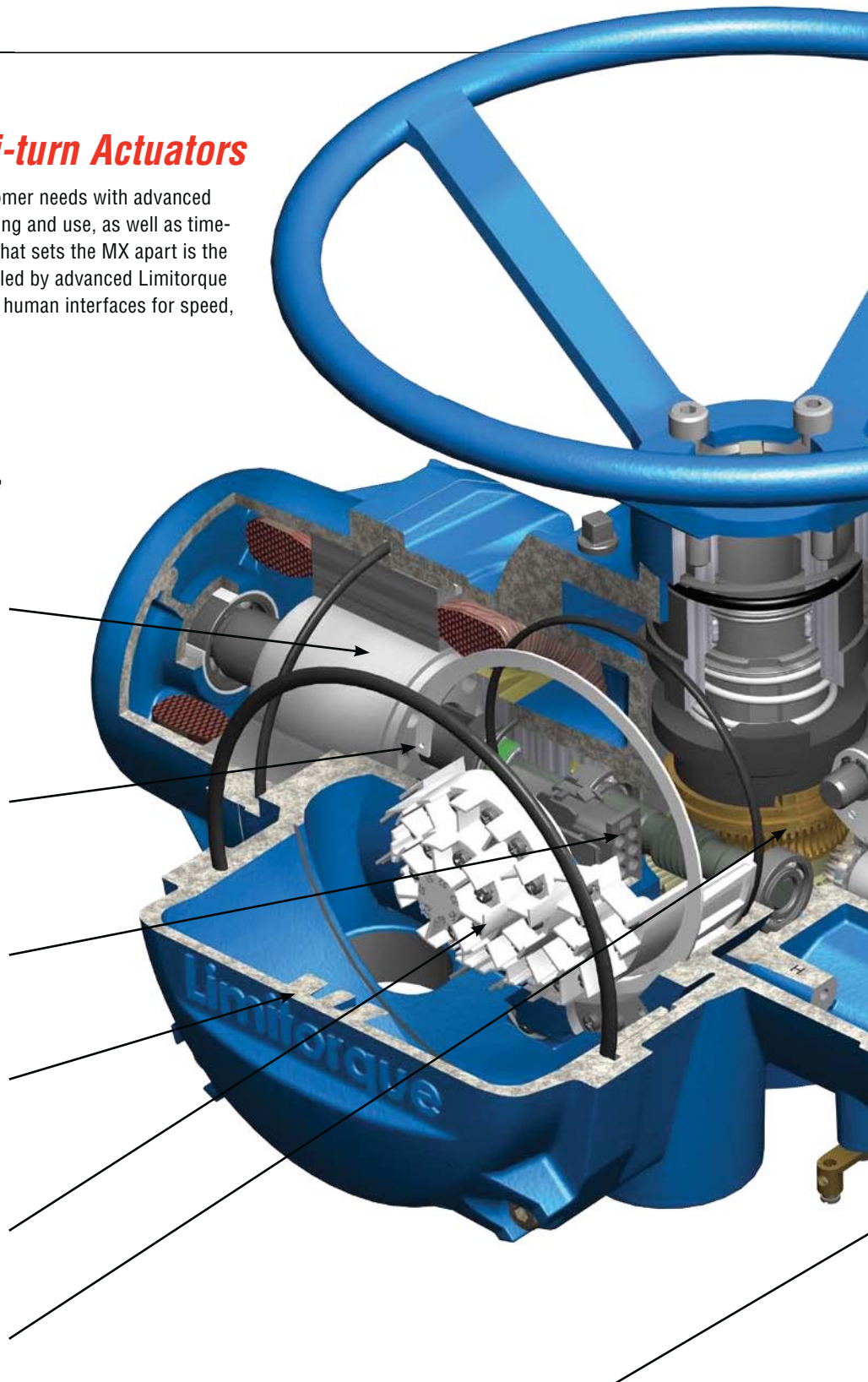



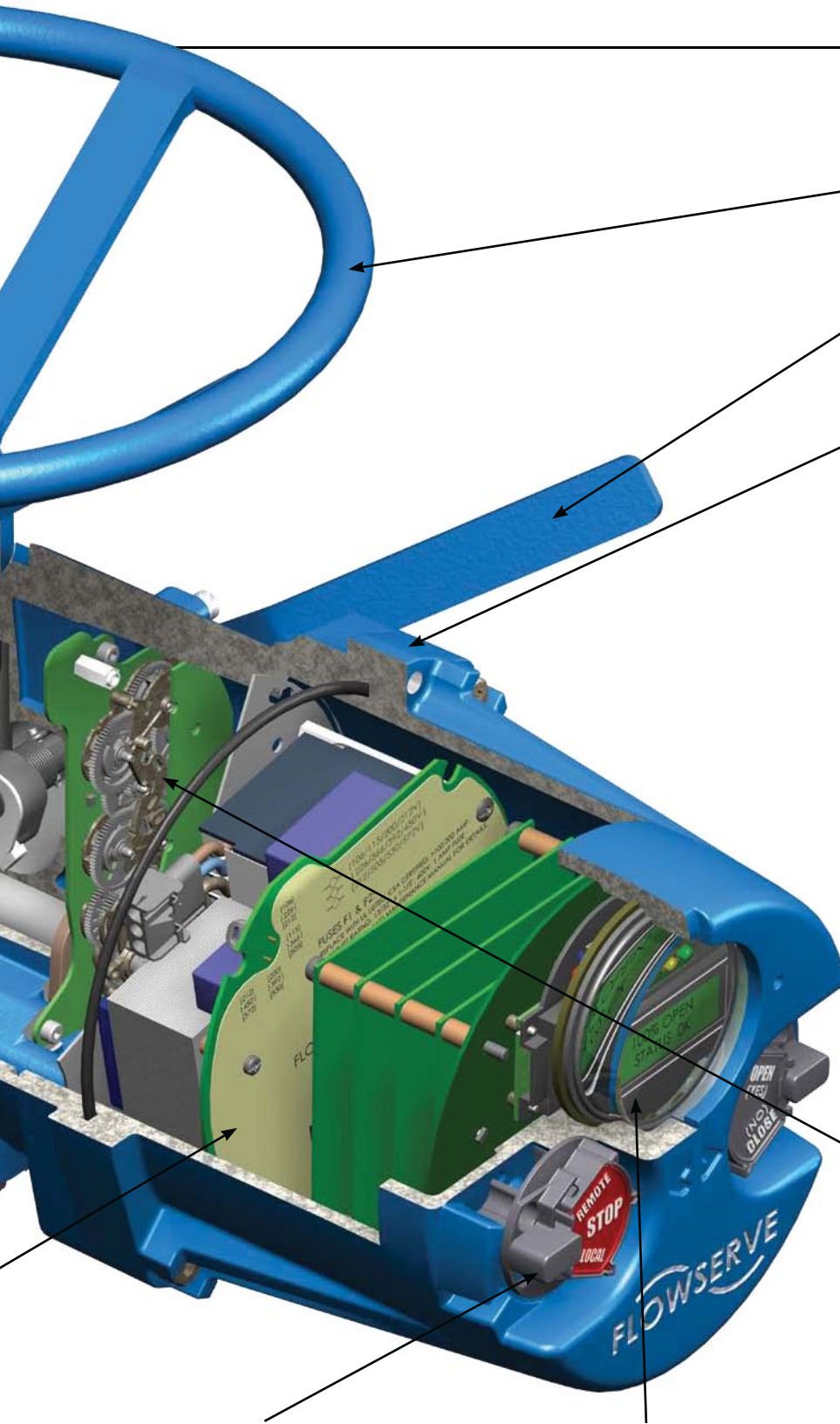

The MX heavy-duty handwheel provides backup for manual operation.

Declutch lever enables the MX actuator to be placed in manual, handwheel-drive operation. Lever automatically disengages when motor is energized and can be padlocked in the motor position.

Cast aluminum housing powder-coated for extreme environments. Optional coatings are available.

Optionally, controls may be powered from an external 24 VDC source as backup for AC power. Controls and display will remain active through loss of AC power.

Torque sensor derives output from motor speed, temperature, and voltage—and shuts off the motor to protect the actuator and valve if the set torque is exceeded. This method of torque scanning indicates Limatorque's commitment to be fully electronic.

Flowserve Limatorque's uncompromising commitment to "no batteries required" is enhanced with the addition of the optional MX Quik (MX-Q) uninterrupted power transfer when mains power is lost to the actuator. MX-Q powers the S/R contacts for updated status to the control room and also provides limited visibility of the LCD screen. It is configurable for "MX Quik time" and, once main power is restored, is available for the next unforeseen power outage.

The absolute encoder, a key that enables MX actuators to achieve 100% repeatable control, provides optical sensing of valve position with 18-bit resolution. The encoder measures valve position in both motor and handwheel operation. No battery or back-up power supply is required. It is now redundant, permitting up to a 50% fault tolerance, ensuring reliable performance in the unlikely event of component failure.

Local control switches make setup and calibration easy, using "yes" or "no" responses to straightforward questions, plus they provide the ability to open, stop, and close the actuator and to select remote or local preferences. These switches are magnetically coupled, solid state Hall effect devices, which eliminate troublesome and fragile reed switches.

The control panel display delivers instant, up-to-the-minute actuator status and valve position in ten languages. It also provides simple calibration and diagnostic information, including motor, identification, hardware data, as well as torque profile log reports.

The MX now offers Bluetooth technology as optional, up to 10 meters. When used with Flowserve Limatorque's Windows CE and Mobile 5 based graphical interface Dashboard™, diagnostic information, which includes FDA (frequency domain analysis) can be transferred easily to a PDA, laptop computer or smart cell phone.

## Control & Diagnostics

Control is expected in a smart actuator. The MX is noted for simplifying valve control automation in three critical methods of control:

- Calibration/set-up
- Normal operation
- Diagnostics & troubleshooting

The MX was the first non-intrusive actuator to equip Users with LCD dialog screens in the language of their choice. MX now uses a graphical dot matrix display that improves the visibility of the display. The use of this type of LCD permits the support of any language. In fact, in addition to English, Spanish, German, French, Italian, and Portuguese, the MX now includes four new languages – Mandarin, Russian, Bahasa Indonesia and Katakana – with a capacity for even more. The orientation of the text can be configured to rotate 180° and diagnostic graphs displayed for clearer data collection.

Simple “Yes” and “No” responses to dialog questions confirm the set-up of the MX via solid state Hall effect devices in both knobs. No special tools or remote devices are required. And the MX is “fit for service”, offering the widest range of configuration menus of any non-intrusive, smart actuator.

Diagnostics should be easy to read and decipher. The MX diagnostic enhancements now offer a BIST (Built In Self Test). The BIST feature is also designed into a state-of-the-

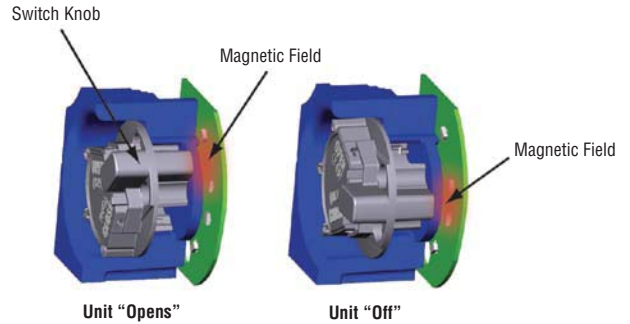

NOTE: Illustration for information only.

Hall effect devices interlocked to prevent operation

art controls platform that verifies and validates the integrity of its components. The result is a design which aids the User in meeting the SIL (Safety Integrity Level) requirements of IEC 61508. While an electronic actuator does not have a SIL rating by itself, placing a smart device into any plant system should enhance the ability of a given safety system to achieve its preferred SIL rating. Any device which incorporates fully developed BIST features provides assurance to the User that the device has been designed with plant-wide safety and integrity of operation in mind.

The “View Diagnostics” menu selections now include more definitive routines which can isolate troubleshooting to “root cause” error codes. These root cause codes can be used in conjunction with BIST. A well designed BIST based system can do more than just report failures in the electronic sub-systems. It can also determine failures or







predict future failures in its associated mechanical system. To further enhance MX diagnostics a new component has been added to the patented Limigard feature – Frequency Domain Analysis.

The Frequency Domain Analysis (FDA) methodology for MX is based upon capturing torque, position or speed values at regular time intervals while the actuator is motoring, then calculating the resulting data set with a Fast Fourier Transform (FFT). This converts the actuator's torque, position or speed signature from time to frequency. The resulting information is very useful at pinpointing any components in the mechanical drive train that have failed, or are about to fail. Only the MX has the FDA feature available in the Dashboard Software.

The MX now offers Bluetooth technology as optional, up to 10 meters. When used with Flowserve Limatorque's Windows CE based graphical software interface Dashboard™, diagnostic information can be transferred easily to a PDA with Windows Mobile 5 platform, laptop computer or smart cell phone. In addition, new firmware can be uploaded (IrDA only) and actuator configurations transferred from one device to any number of subsequent actuators.

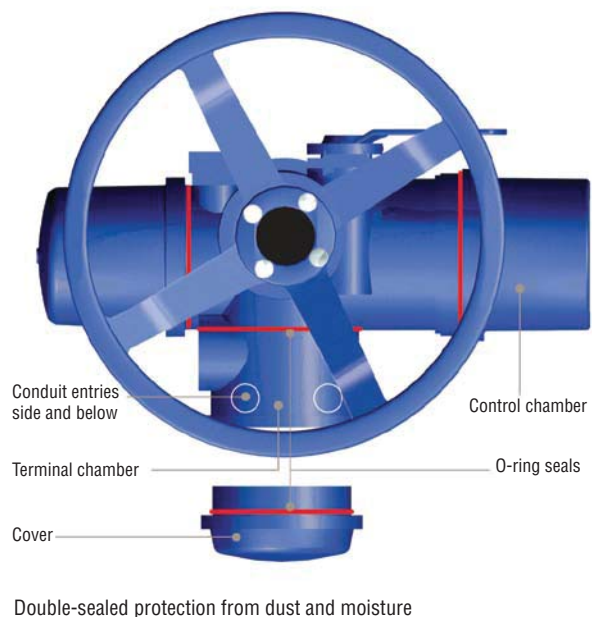

## Nothing exceeds Limitorque MX actuators for ease and compatibility with valves of all types

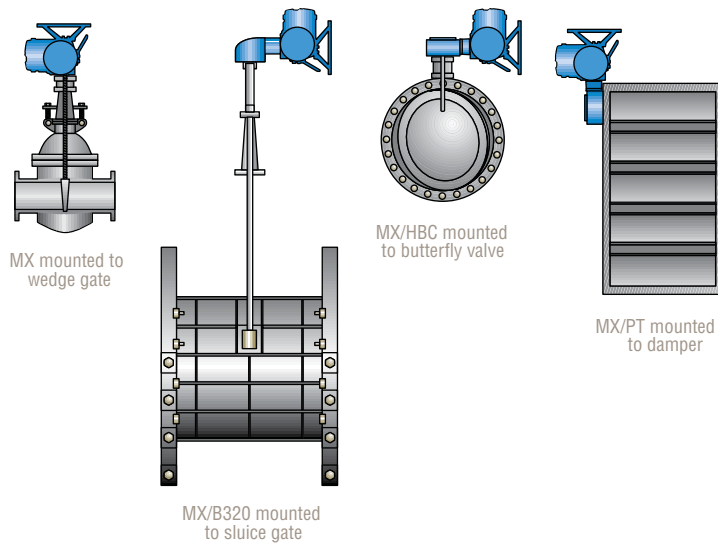

### Valves

Limitorque MX actuators have been designed to accommodate today's wide variety of valve designs and to meet international standards for valve and actuator interfaces, including ISO 5210 and MSS SP-102.

MX actuators are available in a wide variety of configurations to accommodate various applications and valve designs:

**Direct mounting** The MX can be directly coupled with valves for torque-only applications. For thrust applications, a separate thrust base is used.

**MX/HBC/PT** The MX can be coupled to a PT or HBC worm gear reducer for operation of part-turn valves, such as butterflies, balls, plugs, and dampers. This combination provides an output torque capacity of up to 136,000 ft-lb/184,280 N m.

**MX/B320/MT** Rising stem valves may be operated by an MX coupled to a B320 bevel gear reducer. Thrusts up to 325,000 lb/1,445 kN and torque up to 12,000 ft-lb/16,320 N m can be accommodated.

### Couplings

Thrust actuator drive couplings:

- Type A1 – Alloy bronze (thrust)
- Type A1E – Extended bronze nut

Torque-only actuator drive couplings:

- Type B4 – Standard steel bushing
- Type B4E – Extended steel bushing
- Type B1 – Large fixed-bore keyway steel bushing (ISO 5210)
- Type BL – Splined steel bushing for rising rotating stem valves

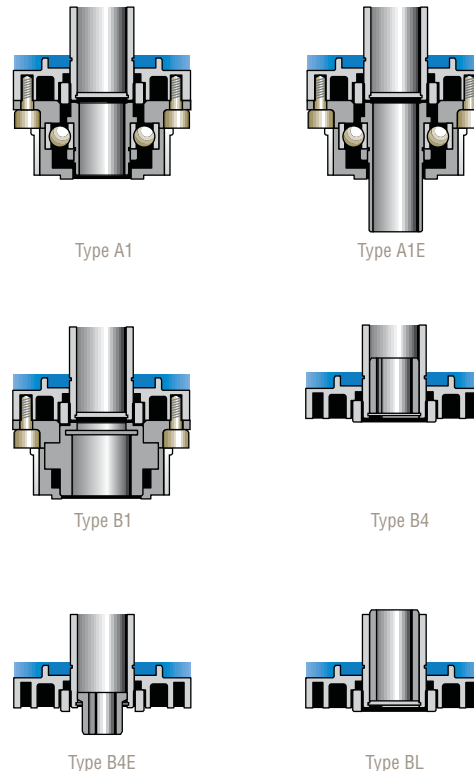
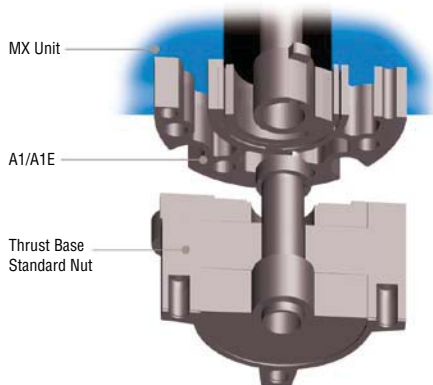



## Integrity and Predictable Performance

Smart actuators should have enabling technologies that ensure integrity and dependability. The MX offers three.

### Limigard — now with BIST and FDA

Enhanced reliability for optimal plant operations and reduced troubleshooting costs are the primary benefits of Limitorque's patented smart actuator monitor: LimiGard.

When LimiGard wiring diagrams are followed, LimiGard continually monitors the control relays, internal logic circuits, and external command signals, comparing them to reference conditions. This virtually eliminates the possibility that an actuator malfunction can occur without prompt detection and alarm communication. In the event of a malfunction, LimiGard takes over and supervises the actuator's response characteristics, maximizing safety and predictability. Fault Insertion Tests confirm this Fail/No-Action philosophy built into every MX actuator.

A state-of-the-art electronic actuator such as the MX should include means for verifying and validating that its components are designed with Built-In-Self-Test (BIST) capabilities. Selecting the MX, which incorporates a high level of BIST, can contribute greatly to the integrity and reliability of process applications and enhance the ability of a safety system to achieve its highest possible SIL rating.

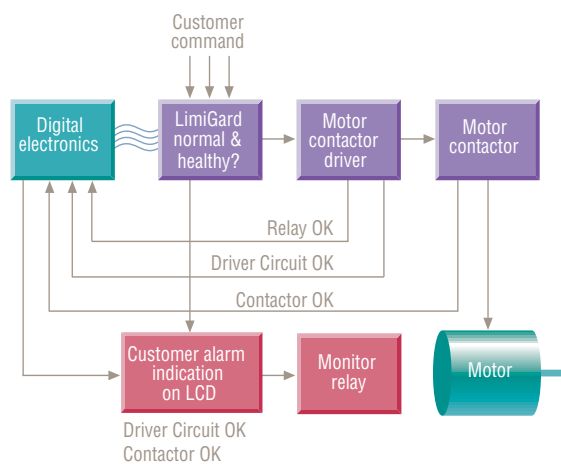

### Absolute position encoder

Limitorque was the first electronic actuator supplier to use an absolute encoder which doesn't require battery back-up for positioning. Customers specify absolute encoders for uninterrupted performance and the MX meets customer expectations with an improved, 18-bit optical, 100% repeatable device. Position information is accurate with or without electrical power. The 18 bits also means that the span of the MX encoder is now almost 10x the original – good for ~10,000 drive sleeve rotations. The encoder has redundant circuits ensuring performance even in the event of up to 50% component failure, continuing to provide reliable data while alerting the user to any faults.



### Torque sensing

Torque limiting has been a Limitorque feature for better than 75 years. In fact, the name Limitorque was coined to identify the ability of an electric actuator to "limit torque" to a valve. In the past, electromechanical actuators have sensed torque using a complicated system of springs, switches and cams. The MX actuator senses torque electronically for use in valve control, overload protection, and torque trending. In conjunction with the Limigard feature, torque is sensed from motor speed, with compensation performed for voltage and temperature variations. The result is highly reliable and predictable torque sensing without the need for the extra components associated with electromechanical torque switches. The MX is a true smart actuator.

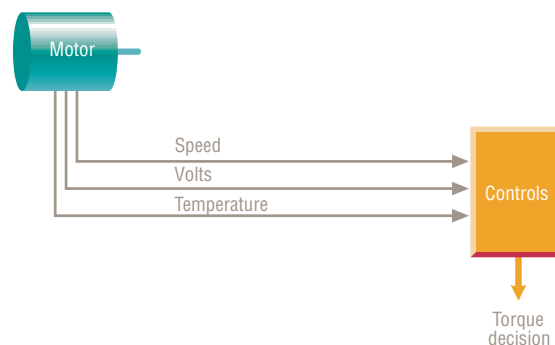

## ***MX Control, Indication, Protection and Optional Features***

### ***Standard features***

- Direct-wired remote control – Wiring flexibility includes the following standard alternatives to open-stop-close the actuator:
  - Four-wire – Valve can be opened, closed, or stopped.
  - Two-wire switched – Single open or closed contact; valve can be opened or closed, but not stopped.
  - Three-wire maintained – Two maintained contacts for self-maintained control. Valve can be opened or closed but not stopped in mid-travel.
  - Three-wire inching – Two momentary contacts; valve can be opened, closed, and stopped in mid-travel.
- Multi-mode control – Three modes of remote control are permitted when the MX is configured for multi-control: digital (discrete) control, analog control or network (fieldbus) control. The MX will respond to the last command received. However, analog (modutronic) control is initiated by either toggling MX User Input 2 (configured for CSE input) or removing and reapplying the 4-20 mA analog signal. Refer to LMENTB2300 for further information.
- Monitor relay – Provides an N/O and N/C contact representing “Actuator available for remote operation.”
- Emergency Shutdown (ESD) – A remote, external ESD signal may be applied to the actuator to move the valve to a predetermined user-configured shutdown position, overriding existing control signals.
- User defined inputs – Three user defined inputs are supplied.
- Inhibit signals – External signals may be used to inhibit actuator opening, closing, or both.
- Control signals – The control signal can be either 24 VDC or optional 125 VAC; it can be sourced from the actuator or customer supply.
- Status contacts (4) – May be set to represent up to 25 actuator conditions.

### ***Protection features***

- Autophase protection and correction – Assures proper open/close directions and monitors and corrects phasing if connected improperly. Prevents operation if a phase is lost.
- Jammed valve – Automatically initiates a forward/reverse cycle to free jammed valves.
- Instantaneous reversal protection – Incorporates the proper time delay between the motor reversals to reduce current surges and extend contactor life.
- Motor thermal protection – A thermistor, placed within the motor, protects against overheating.

- LimiGard™ circuit protection – LimiGard consists of dedicated circuitry that continually monitors the motor controller, control relays, internal logic circuits and external command signals. When the recommended wiring connections are made, it virtually eliminates unexpected, erroneous actuation caused by internal electronic failures and erratic external command signals. Additionally, in the event of malfunction, LimiGard supervises the actuator response, detects the source of the failure and signals an alarm.

### ***Optional features***

- Alarm contacts – Up to eight latched contacts may be set to represent up to 25 key actuator conditions.
- Two-speed timer – A two-speed pulsing timer may be incorporated to support variable stroke times as configured by the user.
- Analog Position Transmitter (APT) – The APT is an internally powered, non-contacting valve position transmitter that provides a 4-20 mA signal proportional to valve position.
- Analog Torque Transmitter (ATT) – The ATT is a non-contacting, internally powered transmitter that provides a 4-20 mA signal that is proportional to actuator output torque.
- Modutronic controller – The Modutronic controller positions the valve in response to an external 4-20 mA command signal. It includes automatic pulsing mode to prevent overshoot at the set point. Parameters that may be set easily during configuration include proportional band, dead band, polarity, and action on loss of command signal.
- Solid State Motor Reverser (SSMR) – An SSMR is available when severe operating conditions demand continuous operation.
- Partial stroke and momentary closure ESD – The partial stroke and momentary closure ESD signals are configurable by the user. It can also be supplied with a momentary closure contact initiated ESD signal routine with redundant circuitry.
- Arctic temperature – The MX is suitable for installation and operation in severely cold climates to -60°C (-76°F). There is no need for external heat sources to supplement the internal power—the MX is predictable and reliable even in the most rugged applications.
- Control Station (CSE) – The CSE is a separate control station designed for the operation of inaccessible actuators. It is available with LEDs, Remote/Local and Open/Close selector switches. The CSE may be powered by the actuator internal supply, provided wire resistance and other external loads do not limit the available signal power presented to the MX.



- Isolation and Load Break Switches – Isolation and Load Break Switches can be supplied for the incoming three-phase supply to the actuator. These may be coupled directly to the actuator for weatherproof (WP) applications only or supplied separately for mounting by user. The enclosure is suitable for weatherproof or temporary submersion service. An explosion-proof (XP) isolation switch is also available for user mounting and is suitable for mounting with all MX actuators. Please contact factory for availability.
- Negative Switching – When remote control systems require the negative pole of the circuit supply to be switched to positive earth, a simple software change is made.
- MX Quik – After the actuator has been powered by line power for one hour, it will automatically withstand most power outages while maintaining the correct state of the S or R status contacts—even if the user repositions the actuator manually with the handwheel. To maximize its self-power time while the line power is lost, the actuator places itself in its lowest possible power usage mode. The LCD will darken

(sleep mode) until it is activated for viewing. The LCD can be activated by moving the black knob to OPEN (YES) or by moving the actuator with the handwheel. After 10 seconds of inactivity, the LCD will return to sleep mode.

### **Bluetooth capable options**

Standard low power wireless communication path to the actuator enables monitoring and configuration of the unit up to 10m in any direction via a Bluetooth equipped PC, PDA, smart cell phone, etc. FHSS (Frequency Hopping Spread Spectrum) allows a reliable communication link even in a “noisy” environment and 128 bit data encryption can be enabled to protect the privacy of the link. MX Dashboard configuration / diagnostics tools can use the Bluetooth link as a means for communicating with the actuator. A visible blue LED in the controls LCD window on the face of the actuator signifies an active Bluetooth link to the actuator has been established.

## **Network Communications**

*The MX provides a comprehensive network option portfolio to the User. Network solutions are improved with the addition of DeviceNet to complement Modbus, FOUNDATION Fieldbus H1, Profibus DP\_V1 and Profibus PA. MX provides the User with predictable, reliable, and safe operation for years to come, in applications which are subject to the most rigorous requirements and environmental extremes.*

### **DDC Modbus (Distributed Digital Control) Communication**

DDC is Flowserve Limatorque’s digital communication control system that provides the ability to control and monitor up to 250 actuators over a single twisted-pair cable. The communication network employs Modbus protocol on an RS-485 network and is redundant. Redundancy assures that any single break or short in the communication cable will not disable any actuators. Each actuator has included an addressable field unit that communicates over the twisted pair network and executes open, close, stop, ESD, and GO TO position commands. The field unit also communicates all actuator status and alarm diagnostic messages over the same communication network.

#### **DDC Network**

- Single-ended loop (consult factory)
- Modbus protocol
- High speed – up to 19.2 k baud

### **Master Station III**

MX units equipped with DDC can be controlled via Flowserve Limatorque’s Master Station III. It includes:

- Host interface – Industry standard Modbus Rtu, ASCII, UDP, and TCP/IP protocols and control
- 5.6” TFT touch-screen display for network configuration status
- Configurable polling sequence priority
- Network time protocol for time synchronization of alarms/ diagnostics data to host device
- Modular hot-swappable redundant design
- E-mail notifications of alarm conditions
- Data/event logging



### ***Foundation Fieldbus communication with Device Type Manager (DTM) technology***

The MX can be fitted with FOUNDATION Fieldbus protocol that complies with the IEC 61158-2 Fieldbus H1 standard. The field unit device is able to support several topologies such as point-to-point, bus with spurs, daisy chain, tree or a combination of these. The FF device has network features that include:

- Link Active Scheduler that controls the system
- High-speed communications up to 31.25 kbits/sec
- Publisher-subscriber communication
- Input and output function blocks
- Device descriptions
- Network communication
- Configurable by user

Link Active Scheduler communication: Fieldbus segments have one active Link Active Scheduler (LAS) at a given time, which is the bus arbiter, and does the following:

- Recognizes and adds new devices to the link
- Removes non-responsive devices from the link
- Schedules control activity in, and communication activity between, devices
- Regularly polls devices for process data
- Distributes a priority-driven token to devices for unscheduled transmissions
- DTM technology includes PID (proportional integral derivative) and partial stroke (PS) feature

### ***PROFIBUS DP V1 communication with DTM***

The MX can be fitted with Profibus DP\_V1 protocol field units that comply with EN50170 Fieldbus Standard for RS-485 communications. The device supports several topologies such as point-to-point, bus with spurs, daisy chain, tree or a combination of these. The PB device has network features that include:

- High-speed communications up to 1.5 Mbps
- Master-to-slave communication
- Standby communication channel
- Analog and digital input and output function blocks
- Device descriptions configurable by user
- High-Speed Data Exchange – Startup Sequence
- Power On / Reset – Power On / Reset of master or slave
- Parameterization – download of parameters into field device (selected during configuration by the user)
- I/O Configuration – download of I/O configuration into the field device (selected during configuration by the user)
- Data Exchange – cyclic data exchange (I/O Data) and field device reports diagnostics
- Redundant Profibus DP with single or multiple – master communications

### ***PROFIBUS PA communication with DTM***

A Profibus PA protocol is available and complies with EN50170 Fieldbus Standard and Fieldbus physical layer per IEC 61158-2 for communications. The device supports several topologies such as point-to-point, bus with spurs, daisy chain, tree or a combination of these. The PB device has network features that include:

- High-speed communications up to 31.25 kbits/s with Manchester coding
- Master-to-slave communication
- Bus powered for 9-32 VDC and 15 mA per actuator
- Standby communication channel
- Analog and digital input and output function blocks
- Device descriptions
- Configurable by user

The Profibus DP-V1/PA DTM V 1.0 is a software component that contains device-specific application information. The DTM can be integrated into engineering and FDT frame applications, such as stand-alone commissioning tools or asset management systems that are equipped with FDT interfaces. FDT technology is independent from any specific communication protocol, device software or host system, allowing any device to be accessed from any DCS host through any protocol.

### ***DeviceNet***

DeviceNet complies with CAN-based protocol and provides the following features:

- DeviceNet Group 2 Server implementation
- Master-to-slave communication
- Bus-powered network interface allows power alarm information to be communicated when actuator loses main power; the actuator does NOT drop off the network when power is lost
- Standard polled I/O connection
- Standard bit strobed I/O connection
- Standard change of state / cyclic I/O connection
- Standard explicit connections defined as:
  - Various assembly objects and sizes that allow the network user to determine how much data to transfer to accommodate network installation data throughput requirements
  - Automatic baud rate detection
  - Node address configurable via local setup menu or via the remote network user
  - Broadcast or group network originated ESD support



## MX Series Performance Ratings for Units 05 through 150

MX-05 through MX-40 (three-phase: 50 Hz/380, 400, 415, and 440 Volt: 60 Hz/208, 230, 380, 460, 525, 575 Volt)

MX-85 through MX-150 (three-phase: 50 Hz/380\*, 400, and 415 Volt: 60 Hz/380, 460, 575 Volt)

\*380/50 multiply by 0.9

Output Speed (RPM)				Rated Output Torque													
				MX-05		MX-10		MX-20		MX-40		MX-85		MX-140		MX-150	
60 Hz		50 Hz		ft-lb	N m	ft-lb	N m	ft-lb	N m	ft-lb	N m	ft-lb	N m	ft-lb	N m		
18	15	55	75	125	170	225	305	440	597	N/A	N/A	N/A	N/A	N/A	N/A		
26	22	55	75	125	170	225	305	440	597	850	1153	1500	2036	N/A	N/A		
40	33	55	75	125	170	225	305	440	597	1225	1662	1700	2307	N/A	N/A		
52	43	55	75	125	170	225	305	440	597	1150	1561	1600	2171	N/A	N/A		
77	65	48	65	107	145	178	241	345	468	850	1153	1200	1628	N/A	N/A		
100	131 <sup>1</sup>	84	110 <sup>1</sup>	39	53	89	121	148	201	286	388	600	814	815	1105	1500	2036
155	170 <sup>1</sup>	127	143 <sup>1</sup>	41	56	89	121	140	190	260	353	450	611	650	882	1150	1561
200	165	34	46	73	99	114	155	210	285	N/A	N/A	N/A	N/A	N/A	N/A	N/A	

Note 1: MX-85, MX-140 and MX-150

	lb	kN	lb	kN	lb	kN	lb	kN	lb	kN	lb	kN	lb	kN
Thrust Ratings (lb/kN)	8000	35	15000	66	25000	111	36000	160	50000	222	75000	333	75000	333
<b>B4 Base (Torque Only)</b>	<b>lb</b>	<b>kg</b>	<b>lb</b>	<b>kg</b>	<b>lb</b>	<b>kg</b>	<b>lb</b>	<b>kg</b>	<b>lb</b>	<b>kg</b>	<b>lb</b>	<b>kg</b>	<b>lb</b>	<b>kg</b>
Weights (lb/kg)	52	24	65	29	109	49	133	60	250	114	300	136	431	182

A1 Base (Thrust Only) Weight	lb	kg
MX-05 & MX-10	9	4
MX-20 & MX-40	29	13
MX-85 w/ F16/FA16 base	72	33
MX-140/MX-150 w/ F25/FA25 base	111	50

### Maximum Stem Capacity

Type A Couplings	in.	mm	in.	mm	in.	mm	in.	mm	in.	mm	in.	mm	in.	mm
Type A1	1.26	32	1.57	40	2.36	60	2.64	67	3.50	88	3.50	88	3.50	88
Type A1E (Extended Nut)	1.26	32	1.57	40	2.36	60	2.64	67	3.50	88	3.50	88	3.50	88
Type B Couplings (Torque Only) <sup>2</sup>	in.	mm	in.	mm	in.	mm	in.	mm	in.	mm	in.	mm	in.	mm
Type B4	1	25.4	1.25	30	1.94	50	2.2	55	2.88	73	2.88	73	2.625	65
Type B4E (Extended)	0.75	19	0.91	22	1.56	41	1.78	46	2.25	57	2.25	57	2.625	65
Type B1 (Fixed Bore) <sup>3</sup>	N/A	42	N/A	42	N/A	60	N/A	60	N/A	N/A	N/A	N/A	N/A	N/A
Type BL (Splined)	6 & 38 Splines		6 & 38 Splines		6 & 36 Splines		6 Splines		N/A	N/A	N/A	N/A	N/A	N/A
Maximum Bore and Keyway	in.	mm	in.	mm	in.	mm	in.	mm	in.	mm	in.	mm	in.	mm
Maximum Bore (B4)	1	25	1.25	30	1.94	50	2.2	55	2.75	65	2.65	65	2.625	65
Maximum Keyway	¼ sq.	8 x 7	¼ sq.	10 x 8	½ x ⅜	14 x 9	½ x ⅜	16 x 10	⅝ x ⅞	18 x 11	⅝ x ⅞	18 x 11	⅝ x ⅞	18 x 11
Maximum Bore (B4E)	.75	18	0.91	22	1.56	41	1.78	46	2.25	56	2.25	56	2.5	65
Maximum Keyway	⅜ sq.	6 x 6	¼ sq.	8 x 7	⅝ sq.	12 x 8	½ x ⅜	14 x 9	½ x ⅜	16 x 10	½ x ⅜	16 x 10	0.625 sq.	18 x 11

Note 2: Maximum bores for Type B couplings may require rectangular keys.

Note 3: Available in ISO base only.

	MX-05	MX-10	MX-20	MX-40	MX-85	MX-140	MX-150
Mounting Base (MSS SP-102/ISO 5210)	FA10/F10	FA10/F10	FA14/F14	FA14/F14	FA16/F16	FA25/F25	FA25/F25
Handwheel Ratio (STD/Optional)	Direct	Direct/8:1	Direct/12:1	Direct/24:1	16/48	16/48	16/48
Side-Mounted Handwheel Efficiencies	N/A	52%	54%	51%	53%/51% <sup>4</sup>	53%/51% <sup>4</sup>	53%/51% <sup>4</sup>

Note 4: Efficiencies for MX-85, MX-140 and 150 are 51% with SGA and 53% without SGA.

## MX Standard & Optional Features

Limitorque MX electronic valve actuators are designed for the operation of ON-OFF and modulating valves. They include a three-phase electric motor, worm gear reduction, absolute encoder, electronic torque sensor, reversing motor contactor, electronic control, protection and monitoring package, handwheel for manual operation, valve interface bushing, 32-character LCD, and local control switches—all contained in an enclosure sealed to NEMA 4, 4X, 6, and IP68. Explosionproof (XP) enclosures can also be provided when required. All MX actuators comply with applicable European Directives and exhibit the CE mark.

### Power transmission and lubrication

All mechanical gearing components are bearing supported, and final drive (output) consists of a hardened alloy steel worm and alloy worm gear. All gears are immersed in an oil-bath lubricated with a synthetic oil designed specifically for extreme pressure worm and worm gear transmission service. Special lubricants are available for operation in temperatures of less than -30°C. Consult factory.

LUBRICATION & TEMPERATURE RANGE	SYNTHETIC BRAND
Standard Lubrication, -30°C to +70°C	Mobil SHC 323
Optional Food Grade Lubrication, -30°C to +70°C	Dow Molykote

### Motor

The MX motor is a 3-phase squirrel cage designed for electronic valve actuators. It is specifically designed for the MX actuator and complies with IEC 34, S2-33 percent duty cycle at 33 percent of rated torque. The motor is a true bolt-on design with a quick-disconnect plug that can be changed rapidly without sacrificing motor leads. It is equipped with

a solid-state motor thermistor to prevent damage due to temperature overloads.

#### ON-OFF MODULATING

Standard insulation class is F to IEC 34, S2-33% for stated operating times 100-600 starts per hour

600-1200 starts per hour, IEC 34, S4\_33%\_1200 S/H

The MX motor permits a global range of 3-phase voltages to be connected without modification. The motor can energize, provided either of the listed voltages are connected:

Phase/Frequency	Application Voltage
3ph - 60 Hz	208, 220, 230, 240, 380, 440, 460, 480, 550, 575, 600
3ph - 50 Hz	380, 400, 415, 440, 525

### Electronic control modules

#### Non-intrusive

The MX is non-intrusive, which means that all calibration/configuration is possible without removing any covers and without the use of any special tools. All calibration is performed in clear text languages; no icons are used. All configuration is performed by answering the “YES” and “NO” questions displayed on the LCD. “YES” is signaled by using the OPEN switch and “NO” by using the CLOSE switch, as indicated adjacent to the switches.

#### Double-sealed terminal compartment and terminal block

All customer connections are located in a terminal chamber that is separately sealed from all other actuator components. Site wiring doesn't expose actuator components to the environment. The internal sealing within the terminal chamber is suitable for NEMA 4, 6, and IP68 to 15M for 96 hours. The terminal block includes screw-type terminals; three for



power and 54 for control. Customer connections are made via conduits located in the terminal housing.

**Three Standard Conduit Openings**  
(NPT threads standard, M optional)

- (2) – 1.25" NPT or M32 (optional)
- (1) – 1.5" NPT (standard) or M38 (optional)

**Controls**

The controls are all solid state and include power and logic circuit boards and a motor controller that performs as the motor reverser, all mounted to a steel plate and attached in the control compartment with captive screws. All internal wiring is flame resistant, rated 105°C, and UL/CSA listed.

The controls are housed in the ACP (Actuator Control Panel) cover, and the logic module uses solid-state Hall-effect devices for local communication and configuration. A 32-character, graphical LCD is included to display valve position as a percent of open, 0-100% and current actuator status. Red and green LEDs are included to signal 'Opened' and 'Closed,' and are reversible, and a yellow LED to indicate 'Valve Moving.' A blue LED is included when the Bluetooth option is ordered. A padlockable LOCAL-STOP-REMOTE switch and an OPEN-CLOSE switch are included for local valve actuator control

Using the knobs and LCD screen the MX is configurable in 10 languages: English, Spanish, French, German, Portuguese, Italian, Mandarin, Russian, Bahasa Indonesia and Katakana.

**S contacts for remote indication**

As standard, two pairs of latched status contacts rated 125 VAC, 0.5 A and 30 VDC, 2 A are provided for remote indication of valve position, configured as 1-N/O and 1-N/C for both the open and closed positions. Two contacts may be configured to represent any other actuator status and the other two will be complementary. The contacts may be configured in any of the selections depicted in the "Actuator Status Message" column.

"S" Contact AC	"S" Contact DC
0.5 Amps @ 125 VAC	1A @ 50 VDC, 2A @ 30 VDC (Resistive)

Actuator Status Message	Function
"CLOSED"	- valve closed "(0% OPEN)"
"OPENED"	- valve open "(100% OPEN)"
"CLOSING"	- valve closing
"OPENING"	- valve opening
"STOPPED"	- valve stopped in mid-travel
"VALVE MOVING"	- either direction
"LOCAL SELECTED"	- red selector knob in "LOCAL"
"MOTOR OVERTEMP"	- thermistor range exceeded
"OVERTORQUE"	- torque exceeded in mid-travel
"MANUAL OVERRIDE"	- actuator moved by handwheel
"VALVE JAMMED"	- valve can't move
"CLOSE TORQUE SW"	- torque switch trip at "CLOSED"
"OPEN TORQUE SW"	- torque switch trip at "OPEN"
"LOCAL STOP/OFF"	- red selector knob at "STOP"
"LOST PHASE"	- one or more of the incoming supply lost
"ESD SIGNAL"	- signal active
"CLOSE INHIBIT"	- close inhibit signal active
"OPEN INHIBIT"	- open inhibit signal active
"ANALOG IP LOST"	- 4-20 mA not present
"REMOTE SELECTED"	- red selector in "REMOTE"
"HARDWARE FAILURE"	- indication
"NETWORK CONTROLLED"	- permits relay control via DDC, FF, or other network driver
"FUNCTION"	- LimiGuard circuit protection activated
"MID-TRAVEL"	- valve position, 1-99% open
"CSE CONTROL"	- CSE station in LOCAL or STOP and controls actuator

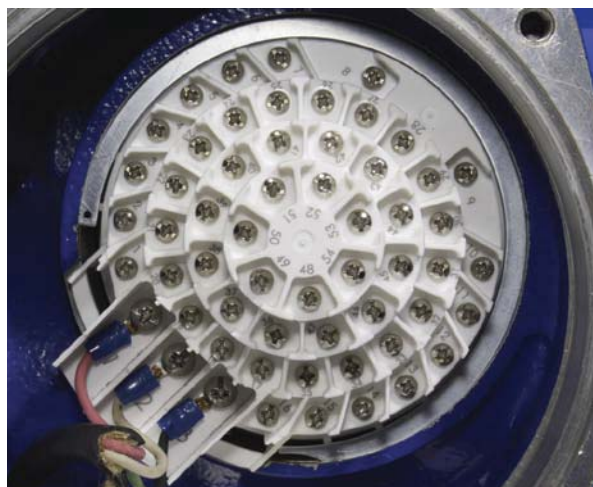





### Monitor relay for remote indication

A monitor relay is included as standard and trips when the actuator is not available for remote operation. Both N/O and N/C contacts are included, rated 125 VAC, 0.5 A and 30 VDC, 2 A. The monitor relay can be configured for three additional fault indications: lost phase, valve jammed and motor Overtemp. The yellow LED will blink when the monitor relay is active. The user can disable the monitor relay, if necessary.

Monitor Relay AC	Monitor Relay DC
0.5 Amps @ 125 VAC	1A @ 50 VDC, 2A @ 30 VDC (Resistive)

### Remote control

Discrete remote control (user supplied) may be configured as two, three or four wires for Open-Stop-Close control. Remote control functions may be powered by external 24 VDC, 110 VAC, or the actuator's internal 24 VDC supply or optional 110 VAC supply. The internal supplies are protected against over current and short circuit faults and utilize optical isolation to minimize electromagnetic interference. Discrete control provides isolated commons for up to three selections.

Signal Threshold for Voltage Values	Maximum Load
5.0 VAC/VDC maximum 'OFF'	24 VDC + 2 mA
19.2 VAC/VDC minimum 'ON'	110 VAC + 10 mA

### Speed control

The MX permits operational speeds in either Open and Closed directions to be set independently of each other. The MX also has an industry leading span for the optional two-speed timer.

Two-Speed Timer Span "ON" Pulse	Two-Speed Timer Span "Off" Pulse
0.5 to 20 seconds (0.5 sec. increments)	1.0 to 200 seconds (1.0 sec. increments)

## Software

### Limigard

A dedicated circuit to prevent undesired valve operation in the event of an internal circuit fault or erratic command signal is included as standard on each Limatorque electronic actuator. A single point failure will not result in erratic actuator movement nor will an open or short circuit in the internal circuit board logic energize the motor controller. The command inputs are optically coupled and require a valid signal pulse width from at least 250 ms to 350 ms to either turn on or off. In the event of an internal circuit fault, an alarm is signaled by tripping the monitor relay and through LCD indication. The control module also includes an auto reversal delay to inhibit high-current surges caused by rapid motor reversals.

### Phase detection and correction (three phase)

A phase correction circuit is included to correct motor rotation faults caused by incorrect site wiring or phase switching in the event of a power down. The phase correction circuit also detects the loss of a phase and disables operation to prevent motor damage. The monitor relay will trip and an error message is displayed on the LCD screen when loss of phase occurs.

### Multi-mode remote control

The MX is capable of being configured for multi-mode remote control, which permits discrete wiring for either two, three or four wires, or network (Fieldbuses) for Open-Stop-Close control and responds to the last signal received. The actuator can also distinguish analog control for modulating applications. The QX and MX products from Limatorque are the only smart actuators with such features.

### ESD

An Emergency Shutdown (ESD) provision is included in each actuator, and the MX has up to three configurable inputs for ESD. The ESD signal(s) can be selected to override any existing signal and send the valve to its configured emergency position. Provision for an isolated common is standard.



### **Inhibits**

The MX has as standard provisions for inhibit movement and also contains up to three configurable inputs. Provision for an isolated common is also standard.

### **Diagnostics**

The MX contains similar diagnostic facilities as the QX. The values are included to accumulate and report the performance of the motor, encoder, motor controller, cycle time, handwheel operations, actuator ID, firmware revision and output turns. In addition, a torque profile of the reference baseline valve stroke and the last valve stroke is included. A feature for resetting the diagnostic odometer is also provided. All diagnostic information is displayed on the LCD and can be acquired over a network if Fieldbus options are purchased. The MX actuator has the ability for diagnostics information to be downloaded to a PC or PDA via both IRDA and Bluetooth ports using the Dashboard software.

Diagnostics also include a Frequency Domain Analysis (FDA) feature. The FDA methodology captures torque, position or speed values at regular time intervals while the actuator is motoring, and calculates the resulting data set with a Fast Fourier Transform (FFT). The resulting information can be used to isolate any components in the mechanical drive train that may exhibit excessive wear or may effect normal actuator operation. The actuator also contains the ability for diagnostics information to be downloaded to a PC or PDA via both IRDA and Bluetooth ports utilizing MX Dashboard.

### **Valve and actuator position sensing**

Valve position is sensed by an 18-bit, optical, absolute position encoder with redundant position sensing circuits designed for Built-In-Self-Test (BIST). Each of the position sensing circuits is redundant, facilitating BIST. The BIST feature discerns which failures will signal a warning only and which require a warning plus safe shutdown of the actuator. Open and closed positions are stored in permanent, nonvolatile memory. The encoder measures valve position at all times, including both motor and handwheel operation, with or without power present, and without the use of a battery. The absolute encoder is capable of resolving  $\pm 7^\circ$  of output shaft position over 10,000 output drive rotations. This design permits continuous monitoring of valve position during motor and handwheel operation. The encoder is 100% repeatable and requires no backup power source for operation. The output is used to control the open and closed valve position and measure and report valve position, as well as provide local and remote position feedback. The positioning accuracy is better than 99% for valves requiring 50 or more turns.

- Maximum actuator turns = 10,000
- Resolution =  $\pm 7$  degrees

### Valve and actuator torque sensing

The MX and QX are the only electric actuators that sense torque electronically. A microprocessor calculates output torque from motor speed, voltage, and temperature. Torque limit may be set from 40–100% of rating in 1% increments. A boost circuit is included to prevent torque trip during initial valve unseating and in cold climates. A “Jammed Valve Protection” feature, with automatic retry sequence, is included to de-energize the motor if the output torque requirement exceeds the boost torque. A boost function is included to prevent torque trip during initial valve unseating and during extreme arctic temperature operation (from 0°C down to -60°C). The MX monitors for “jammed valve” as a protection feature and initiates an automatic retry sequence if no movement occurs.

### Exterior corrosion protection

The MX actuator is coated with as standard a polymer powder coat suitable for exposure to an ASTM B117 salt spray test of 1,500 hours. External fasteners are 300 series stainless steel. Optional coatings are available by contacting factory.

### Manual operation

A handwheel and declutch lever are provided for manual operation. The handwheel is metal and changing from motor to manual operation is accomplished by engaging the declutch lever. Energizing the motor returns the MX to motor operation. The lever is padlockable in either motor or manual operation. Optional configurations for handwheels are available by consulting the factory.

### Factory testing

Every MX actuator is factory tested to verify rated output torque, output speed, handwheel operation, local control, control power supply, valve jammed function, all customer inputs and outputs, motor current, motor thermistor, LCD and LED operation, direction of rotation, microprocessor checks and position-sensor checks. A report confirming successful completion of testing is included with the actuator. Special testing can also be performed by contacting the factory.

### Design life and endurance testing

- Design Life - One million drive sleeve turns is considered typical life expectancy under normal operating conditions approved ambient working environments.
- Endurance – 50 million collective drive sleeve turns of endurance testing were performed on the MX for proof of design.
- AWWA C540-02 – “Standard for Power Actuating Devices for Valves and Sluice Gates” – 10,000 cycles with confirmation of specified torque and position accuracy.

### Options

#### Lost power buffer and 24 VDC UPS

Terminals are included and can be used to optionally connect the electronic controls package, including display, to a backup 24 VDC power source. Another option is the MX Quik. Once the actuator has been powered by line power for one hour, it can automatically withstand most power outages while maintaining the correct state of the alarm and status contacts, even if the user repositions the actuator manually with the handwheel. To maximize its self-power time while the line power is lost, the actuator will place itself in its lowest possible power usage mode. The LCD will darken (sleep mode) until it is needed to be viewed. The LCD can be activated by moving the black knob to OPEN (YES) or by moving the actuator with the handwheel. After 7-8 seconds of inactivity, the LCD will return to sleep mode. This feature can last up to three hours and automatically recharges once main power is restored.

The use of batteries to perform this function is not required.

#### Analog Position Transmitter (APT)

A non-contacting, internally powered, electrically isolated position transmitter can be included to provide a 4-20 mA or 0-10 VDC signal that is proportional to valve position.

#### Analog Torque Transmitter (ATT)

A non-contacting, internally powered, electrically isolated torque transmitter can be included to provide a 4-20 mA or 0-10 VDC signal that is proportional to rated output torque.

Voltages or Currents for APT/ATT	Maximum/Minimum External Load - APT/ATT
4-20 mA	470 ohms - 99.9% accuracy/ 750 ohms for 99% accuracy
0-10 VDC	1000 ohms minimum - 99.9% accuracy/ 2700 ohms minimum - 99% accuracy



**Modutronic option**

A controller that alters valve position in proportion to a 4-20 mA analog command signal can be ordered. Positioning is accomplished by comparing the command signal to a non-contacting internal position feedback. An automatic pulsing feature to prevent overshoot at the setpoint is included. Proportional bands, deadband, signal polarity, motion inhibits time, and fail are adjustable using either the Local control mode of configuration or MX/QX Dashboard. Deadband is adjustable to 0.5 percent full span.

Voltages or Currents for Modulation	Input Impedance/Capacitance
4-20 mA	150 ohms Impedance
0-10 VDC	0.1 $\mu$ F +/- 30%

**Relays for status and alarms**

Up to eight additional latching output contacts rated 250 VAC/30 VDC, 5 A and configurable to represent any actuator status in either N/O or N/C state are available. Please refer to “Status and Alarm Contacts for Remote Indication” for list of settings.

“R” Contact and Monitor Relay AC Ratings	“S” Contact and Monitor Relay DC Ratings
5.0 Amps @ 250 VAC	1A @ 50 VDC, 5A @ 30 VDC (Resistive)

**Custom software—Momentary contact ESD and partial stroke ESD**

An optional, custom software is available which, when combined with the unique safety features of the MX actuator, permits a unique scope of performance for partial stroke and emergency shutdown installations.

When enabled a user may set up the partial stroke and ESD signals as redundant digital inputs for safety. There are two signal inputs for either selection, and both must be in the active state in order for the specific function to occur.

If the partial stroke enable inputs are not active, in a fault state, or are released by the control logic and a signal is detected on the momentary ESD/PSESD input, then the actuator will perform the configured ESD operation. The momentary ESD/PSESD input will be ignored if there is a signal present for less than 100 msec, and is guaranteed to latch in the ESD/PSESD if the signal is present for greater than 800 msec. ESD is active until the control logic ESD release is given.

Please contact factory for application and purchase.



## Global Certifications

Non-hazardous (weatherproof / submersion) certifications  
IEC 529 protection code IP68; 15 meters for 96 hours  
USA & CSA; NEMA 3, 4, NEMA 4X, NEMA 6

Geographic Locations	Weatherproof/ Submersion	Standard Temperature	Optional Temperature
IEC 529 Protection Code IP68	15M for 96 hours	-30°C to +70°C (-22°F to 156°F)	-50°C to +50°C (-58°F to 122°F)
USA & Canada, NEMA 3, 4, 6	20 ft. for 24 hours	-30°C to +70°C (-22°F to 156°F)	-50°C to +50°C (-58°F to 122°F)
USA & Canada, NEMA 4X	1500 hrs. to ASTM B117	-30°C to +70°C (-22°F to 156°F)	-50°C to +50°C (-58°F to 122°F)

### Standard hazardous global certifications

FM – Class I, Groups B, C & D, Div. 1 and Class II, Groups E, F and G, T4

ATEX EExd IIB T4 ATEX II 2 G, CENELEC Norm EN 60079-0:2006 and EN 60079-1:2004

ATEX EExd IIC T4 ATEX II 2 G, CENELEC Norm EN60079-1:2004

EEx de IIB T4 ATEX II G, Increased Safety, CENELEC Norm EN 60079-7:2003

ATEX EEx de II C T4

CSA – Class I, Group C & D, Div. 1 and Class II, Groups E, F & G, T4

GOST and GOST R to GOST 12.2.007.0-75; GOST R 51330.0-99; GOST R 51330.1-99

GOST R 51330.8-99; Rules for electric devices (7.3).

GOST-K, No. KCC007776

Geographic Locations	Explosionproof Classifications	Standard Temperature	Optional Temperature (1)	Optional Temperature (2)
USA to Factory Mutual (FM)	Class I, Groups B, C, & D, Div. 1, T4 and  Class II, Groups E, F, & G, Div. 2, T4	-30°C to +65°C (-22°F to 149°F)	-40°C to +50°C (-40°F to 122°F)	-50°C to +40°C (-58°F to 104°F)
Canada to Canadian Standards Association	Class I, Groups B, C, & D, Div. 1, T4 and  Class II, Groups E, F, & G, Div. 2, T4	-30°C to +65°C (-22°F to 149°F)	-40°C to +50°C (-40°F to 122°F)	-50°C to +40°C (-58°F to 104°F)
ATEX II 2 G, CENELEC Norm EN 50014 & 50018	Eex d IIB T4, Eex d IIC T4, and Eex de IIB T4, Eex de IIC T4	-30°C to +65°C (-22°F to 149°F)	-40°C to +50°C (-40°F to 122°F)	-60°C to +40°C (-76°F to 104°F)
ANZEX	Ex d IIB T4 & Ex de IIB T4 and Ex d IIC T4 & Ex de IIC T4	-30°C to +65°C (-22°F to 149°F)	NA	NA

NOTE: Options are available to -60°C for GOST and GOST-R.

### European directives

All MX actuator designs have been tested to comply with pertinent EU Directives and shipped with the Declaration of Conformity listed in the Regulatory Section of LMENIM2306 and LMENIM2314. The actuator is also tagged with the CE mark to demonstrate compatibility with the following European Directives:

All MX actuator designs have been tested to demonstrate compatibility with the following European directives and are marked with the CE label:

- 89/392/EC - Machinery Directive
- Vibration and seismic capability is in accordance with MILSTD-167, IEEE-344-1975, and IEC68-2-6. Test performed in each of three (3) axes, H1, horizontal – parallel to motor, H2, horizontal – perpendicular to motor, and “V1,” vertical.

Vibration Levels (MX functions after event)	Seismic Levels (MX functions after event)
5-100-5 Hz sweeps at 0.75g acceleration in 3 axes	5.0g acceleration from 3.5 – 31 - 3.5 Hz sine dwells in 3 axes
2-35-1 Hz sweeps at 1.0 g acceleration in 3 axes	3.0g acceleration from 35 - 200 Hz sine dwells in 3 axes
1-500-1 Hz sweeps @ 2.0 g acceleration in 3 axes	
25 Hz dwell @ 2.0 g acceleration in 3 axes	

- Drop test – ASTM-D3332-88, method A
- 2003/10/EC -Airborne Noise to EN 60204-1  
The MX has been tested for noise emissions and at 1 m distance is less than 74 dB per grade A noise requirement of MIL-STD-740 and ANSI/ISA-S82.01-1994 (harmonized std. to IEC 1010-1).
- 2004/108/EC -EMC – Electromagnetic Compatibility and 93/68/EC -Low Voltage; EN 50081-1 & 2 – actuator complies with all pertinent requirements of Class A service categories in the listed table.

### Conduit entries

Three threaded conduit entries are provided tapped: 1 x 1½” and 2 x 1¼” NPT. Unless otherwise specified, actuator will be dispatched with adapters: 1 x M40 and 2 x M32 metric to BS3643, PG adapters are available upon request.

Applicable Emissions standards	EN50011:1998	Class A service	
Radiated emissions	EN55011:1998 & FCC Part 15, subpart J	30-130MHz 40dBmV / m 230-1000MHz 47dBmV / m	
Conducted emissions	EN55011:1998 & FCC Part 15, subpart J	0.15 to 0.5MHz 79dBmV (QuasiPeak 66dBmV avg) 0.5 to 30MHz 73dBmV (QuasiPeak 60dBmV avg)	
Applicable immunity standards	IEC EN 61000-6-1:2001		
ESD	IEC61000-4-1:1995	±8kV thru air ±4kV thru contact	
Radiated RF immunity	IEC61000-4-3:1995	80MHz to 2GHz 10Vrms / m	
Fast transients/burst	IEC61000-4-4:1995	EFT AC Power leads: ±2kV Signal leads: ±1kV	
Voltage surges	IEC61000-4-5:2001	AC Power: ±2kV com, ±1kV diff Signal leads: ±0.5V com, ±1kV diff	Perf criterion: B
Conducted RF immunity	IEC61000-4-6:1996	150kHz to 80MHz 10Vrms	Perf criterion: A w/ 80% AM modulation @ 1KHz
Magnetic field immunity	IEC61000-4-8:1993	Power line frequency 30A/m @ 60Hz	Perf criterion: A
Voltage dips and interrupts	IEC6326-1:2005 (IEC61000-4-11:2004)	60Hz 100% dip, 1 cycle duration 40% dip, 10 cycle duration 70% dip, 25 cycle duration 100% interrupt for 5s	Perf criterion: B, C 3 test each @ 10 sec interval 3 test each @ 10 sec interval 3 test each @ 10 sec interval 3 test each @ 10 sec interval

- Di-electric – Motor per NEMA MG1-12.02 and .03 with leakage of less than 10 mA. Control terminals per IEC-1131-2 and CSA C22.2 with check against physical breakdown.







FCD LMENBR2302-03 Printed in USA.

**To find your local Flowserve representative:**

For more information about Flowserve Corporation, visit [www.flowserve.com](http://www.flowserve.com) or call USA 1 800 225 6989

Flowserve Corporation has established industry leadership in the design and manufacture of its products. When properly selected, this Flowserve product is designed to perform its intended function safely during its useful life. However, the purchaser or user of Flowserve products should be aware that Flowserve products might be used in numerous applications under a wide variety of industrial service conditions. Although Flowserve can (and often does) provide general guidelines, it cannot provide specific data and warnings for all possible applications. The purchaser/user must therefore assume the ultimate responsibility for the proper sizing and selection, installation, operation, and maintenance of Flowserve products. The purchaser/user should read and understand the Installation Operation Maintenance (IOM) instructions included with the product, and train its employees and contractors in the safe use of Flowserve products in connection with the specific application.

While the information and specifications contained in this literature are believed to be accurate, they are supplied for informative purposes only and should not be considered certified or as a guarantee of satisfactory results by reliance thereon. Nothing contained herein is to be construed as a warranty or guarantee, express or implied, regarding any matter with respect to this product. Because Flowserve is continually improving and upgrading its product design, the specifications, dimensions and information contained herein are subject to change without notice. Should any question arise concerning these provisions, the purchaser/user should contact Flowserve Corporation at any one of its worldwide operations or offices.

© 2010 Flowserve Corporation, Irving, Texas, USA. Flowserve is a registered trademark of Flowserve Corporation.

**Flowserve Corporation  
Flow Control**

**United States**

Flowserve Limatorque  
5114 Woodall Road  
P.O. Box 11318  
Lynchburg, VA 24506-1318  
Phone: 434-528-4400  
Facsimile: 434-845-9736

**England**

Flowserve Limatorque  
Euro House  
Abex Road  
Newbury  
Berkshire, RG14 5EY  
United Kingdom  
Phone: 44-1-635-46999  
Facsimile: 44-1-635-36034

**Japan**

Limatorque – Nippon Gear Co., Ltd.  
Asahi-Seimei Bldg. 4th Floor  
1-11-11 Kita-Saiwai, Nishi-Ku  
Yokohama-Shi, (220-0004)  
Japan  
Phone: 81-45-326-2065  
Facsimile: 81-45-320-5962

**Canada**

Flowserve Limatorque  
120 Vinyl Court  
Woodbridge, Ontario L4L 4A3  
Canada  
Phone: 905-856-4565  
Facsimile: 905-856-7905

**Singapore**

Flowserve Limatorque  
12, Tuas Avenue 20  
Singapore 638824  
Phone: 65-6868-4628  
Facsimile: 65-6862-4940

**China**

Limatorque Beijing, Pte., Ltd.  
RM A1/A2  
22/F, East Area, Hanwei Plaza  
No. 7 Guanghua Road, Chaoyang District  
Beijing 100004, Peoples Republic of China  
Phone: 86-10-5921-0606  
Facsimile: 86-10-6561-2702

**India**

Flowserve Limatorque  
No.10-12, THE OVAL, Third floor  
Venkatnarayana Road  
T. Nagar, Chennai 600 017  
Phone: +91-44-2432-8755  
& +91-44-2432-4801  
Facsimile: +91-44-2432-8754