



Limitorque™ LRP

Limitorque Rack & Pinion Pneumatic Actuator



Experience In Motion

LRP Limitorque Rack and Pinion Actuator Series

Limitorque is the brand customers trust when safe, reliable and robust valve automation is demanded in the most arduous operating conditions. Used in a vast range of industries, including oil and gas, petrochemical, power generation, pharmaceutical, and steel production, the Limitorque range of electric, scotch yoke and rack and pinion actuators guarantee precision valve control in challenging applications. The Limitorque LRP provides durable functionality and prolonged service life through unique features such as piston support rods within the actuator, ensuring that side loads generated by the pistons are transmitted through bearings in the end cap and not the body. This eliminates the need for the body to be used as a loadbearing surface and promotes longer service life. The support rod design of the Limitorque LRP actuator distinguishes it from the standard rack and pinion design and offers reliable operation, performance stability and longer service life.

In addition to offering improved operational safety and ease of maintenance, the modular LRP design provides greater application flexibility for easy fitting and interchangeability of ancillary equipment, making it one of the finest pneumatic actuators available today.

Key Benefits

Robust design for durable functionality and maximum ease of use

- Balanced double rack and pinion provides a linear torque curve with a large range of sizes for efficient torque matching
- Mounting to ISO 5211 pattern and DIN 3337 female star drive provides common and simple actuator to valve attachment
- Position indicator - provides highly visible external indication of valve position
- Foolproof location pin for correct assembly
- Multi-spring concept - allows variable torque/air pressure requirements from the same actuator by changing spring quantity
- Namur VDI/VDE 3845 top mounting pattern - for easy fitting and interchangeability of switches, positioners, etc
- Namur VDI/VDE 3845 end-cap solenoid mounting pattern - facilitates interchangeability of solenoids or direct port connections
- Compact fail-safe size as per double-acting - minimizes space requirements

Reduced maintenance and Longer Service life

- Anodised aluminium construction - for anti-corrosion and superior wear performance on internal surfaces, plus stainless steel fasteners and corrosion-protected springs
- One piece steel pinion drive with full width piston tooth engagement - for greater operational life

Increased plant and personnel safety

- For fail-safe operation in a fire, polished support rods retain fire-safe capability even if bearings are fire damaged
- Blow-out proof pinion - eliminates risk of pinion ejection even after pinion retaining ring is removed
- Unique unrestricted air flow through support rods gives fast operation speeds as standard - and also provides greater safety (center chamber cannot be pressurized with end cap removed)
- Long end cap screws allow complete release of spring energy for safe removal of end caps.

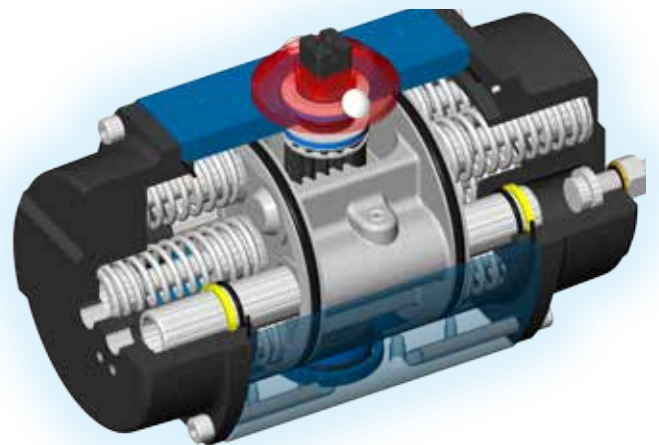

Operating Principle

The LRP pneumatic actuator is based on the opposed double rack and pinion principle but utilises unique support rods to transfer air between the chambers of the actuator and minimise friction and wear between pistons and body bore

Double Acting Actuators

In the double acting model, compressed air is applied to Port 1, which is fed via the large bore support rod into the centre chamber. This forces the pistons apart and turns the actuator's output drive anti-clockwise (seen from above) for valve opening, simultaneously venting the air in the end chambers via the second support rod through Port 2. This operation can be reversed by supplying air into Port 2 for clockwise rotation (valve closing).

Spring Return Actuators

With the fail-safe spring return model, air is applied in a similar way to Port 1 for anti-clockwise operation (valve opening) and the movement of the pistons compresses the springs held in the end chambers of the actuator. This position will be maintained until air pressure is released when the spring force closes the pistons together for clockwise operation (valve closing).

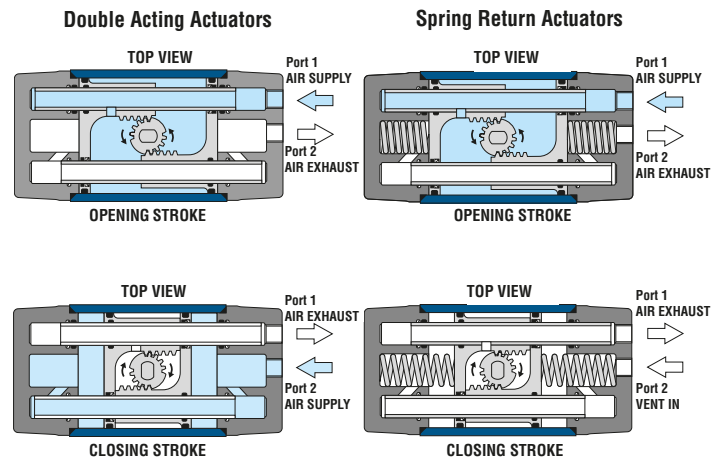

Parts List/Material Specifications

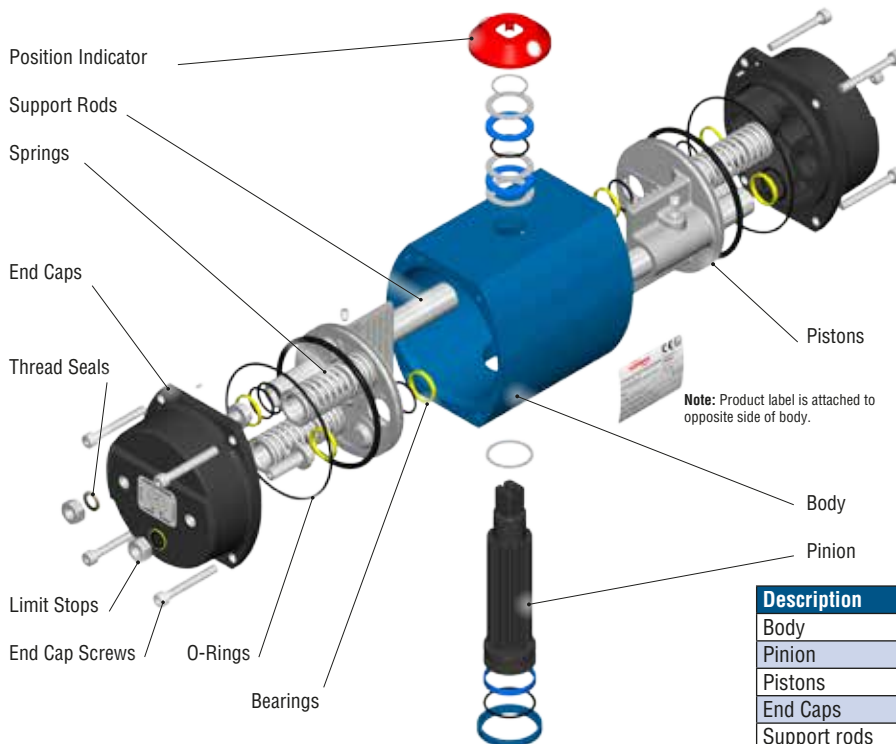

Description	Material/Finish
Body	Aluminium (extrusion) anodised
Pinion	Carbon Steel (corrosion resistant coated)
Pistons	Aluminium
End Caps	Aluminium anodised
Support rods	Stainless Steel
Bearings	Acetal
O-Rings	Nitrile Rubber
End Cap Screws	Stainless Steel
Springs	Chrome Silicon Steel (corrosion resistant coated)
Position Indicator	Polyethylene
Limit Stops	Stainless Steel (Sizes 40 to 50 carbon steel plated)
Thread Seals	Bonded Nitrile and Steel (corrosion resistant coated)

Additional Information

Working Pressure	8.3 bar (120 psig) Maximum. For higher pressures contact our sales office.
Media	Air or non-corrosive fluid
Temperature Range	Standard -20°C to +100°C Low temperature variant -40°C to +85°C* High temperature variant -20°C to +150°C
ATEX	Conforms to ATEX 2014/34/EU under equipment group II, category 2 (non-mining)
SIL	Certified to IEC61508 to SIL level 3 capability

* Please contact Technical Sales for options down to -40 °C

<p>Rotation</p> <p>When viewed from top, piston rotates anti-clockwise when centre chamber supply port 1 is pressurised (see page 3)</p> <p>Limit Stop:</p> <ul style="list-style-type: none"> Nominal 96° total travel including nominal 3° adjustable overtravel and adjustable 10° undertravel both clockwise and anti-clockwise.
<p>Mounting Configurations</p> <p>Solenoid:</p> <ul style="list-style-type: none"> EN15714-3 VDI/VDE 3845 mounting pattern <p>Top Mount Interface:</p> <ul style="list-style-type: none"> EN15714-3 VDI/VDE 3845 mounting pattern <p>Actuator/Valve Interface:</p> <ul style="list-style-type: none"> ISO 5211 pattern with DIN3337 Star drive pinion (female)

Actuator Sizing

The torque tables detailed below provide actual torque values for the range of actuators at typical pressure and spring configurations. **When sizing a valve, we recommend that a factor of safety is applied to its nominal torque. Please contact Technical Sales for further advice.**

Double Acting Actuators

For a given air supply pressure the double acting actuator provides a linear (constant) torque output throughout its rotation (see chart below).

Double Acting Actuator Output Torque Nm (lbf/in)

Size / Series	Operating Pressure barg (psig)										
	2 (29)	2,5 (36)	3 (44)	3,5 (51)	4 (58)	4,5 (65)	5 (73)	5,5 (80)	6 (87)	7 (102)	8 (116)
LRP-10	10	13	16	19	22	25	28	31	34	40	46
	89	115	142	168	195	221	248	274	301	354	407
LRP-15	20	26	31	37	43	49	54	60	66	77	88
	177	230	274	327	381	434	478	531	584	681	779
LRP-20	37	47	57	68	78	89	99	109	120	141	162
	327	416	504	602	690	788	876	965	1062	1248	1434
LRP-25	61	78	96	113	131	148	165	183	200	235	270
	540	690	850	1000	1159	1310	1460	1620	1770	2080	2390
LRP-30	100	129	157	186	214	243	272	300	329	386	443
	885	1142	1389	1646	1894	2151	2407	2655	2912	3416	3921
LRP-33	196	252	308	363	419	475	531	587	643	755	867
	1735	2230	2726	3213	3708	4204	4699	5195	5691	6682	7673
LRP-35	240	309	377	446	515	583	652	720	789	926	1063
	2124	2735	3336	3947	4558	5160	5770	6372	6983	8195	9408
LRP-40	383	492	602	711	821	931	1040	1149	1259	1478	1697
	3390	4354	5328	6292	7266	8239	9204	10169	11142	13080	15018

Spring Return Actuators

The table below shows actuator start and end torque by air and by spring, valid for both fail open and fail close configurations. During sizing, ensure that the actuator has sufficient torque to open and close the valve.

Spring return Actuator Output Torque Nm (lbf/in)

Size / Series	Number of Springs	Spring Stroke		Air Stroke																		
		Start	End	2.5 bar (g) 29 psi (g)		3.0 bar (g) 36 psi (g)		3.5 bar (g) 44 psi (g)		4.0 bar (g) 51 psi (g)		4.5 bar (g) 58 psi (g)		5.0 bar (g) 65 psi (g)		5.5 bar (g) 80 psi (g)		6.0 bar (g) 87 psi (g)		7.0 bar (g) 102 psi (g)		
				Start	End	Start	End	Start	End	Start	End	Start	End	Start	End	Start	End	Start	End	Start	End	
LRP-10	4	8	5	9	6	12	8															
		71	44	80	53	106	71															
	6	12	7			10	5	12	7	15	10											
		106	62			89	44	106	62	133	89											
LRP-15	8	16	10							13	6	16	9	18	11							
		142	89							115	53	142	80	159	97							
	10	20	12											16	8	19	10	22	13	27	18	
		177	106											142	71	168	89	195	115	239	159	
LRP-20	4	13	8	18	13	24	18															
		115	71	159	115	212	159															
	6	20	13			20	12	25	17	30	22											
		177	115			177	106	221	150	266	195											
LRP-25	8	26	17							26	16	31	21	37	26							
		230	150							230	142	274	186	327	230							
	10	33	21											33	20	38	25	43	30	54	40	
		292	186											292	177	336	221	381	266	478	354	
LRP-30	4	24	15	34	24	43	33															
		212	133	301	212	381	292															
	6	36	24			36	22	46	31	55	40											
		319	212			319	195	407	274	487	354											
LRP-35	8	47	31							48	29	57	38	67	48							
		416	274							425	257	504	336	593	425							
	10	59	38									50	27	59	36	69	46	79	55	99	73	
		522	336									443	239	522	319	611	407	699	487	876	646	
LRP-40	4	43	26	55	37	72	52															
		381	230	487	327	637	460															
	6	64	39			59	32	75	47	91	63											
		566	345			522	283	664	416	805	558											
LRP-45	8	86	53							78	43	94	58	111	73							
		761	469							690	381	832	513	982	646							
	10	107	66											98	53	114	69	130	84	163	115	
		947	584											867	469	1009	611	1151	743	1443	1018	
LRP-50	4	69	42	92	62	119	87															
		611	372	814	549	1053	770															
	6	103	63			98	54	125	80	151	105											
		912	558			867	478	1106	708	1336	929											
LRP-60	8	138	84							130	72	157	98	184	123							
		1221	743							1151	637	1389	867	1628	1089							
	10	172	105											163	91	190	116	217	141	270	192	
		1522	929											1443	805	1682	1027	1920	1248	2390	1699	
LRP-70	4	142	91	171	113	224	163															
		1257	805	1513	1000	1982	1443															
	6	213	136			178	96	231	145	283	195											
		1885	1204			1575	850	2044	1283	2505	1726											
LRP-80	8	284	182							238	127	290	177	343	226							
		2513	1611							2106	1124	2567	1566	3036	2000							
	10	356	227											297	159	250	209	402	258	510	357	
		3151	2009											2628	1407	2213	1850	3558	2283	4514	3159	
LRP-90	4	164	105	217	149	281	210															
		1451	929	1920	1319	2487	1859															
	6	246	158			228	132	293	193	357	254											
		2177	1398			2018	1168	2593	1708	3159	2248											
LRP-100	8	328	210							304	176	369	237	433	298							
		2903	1859							2690	1558	3266	2097	3832	2637							
	10	410	263											381	220	445	281	509	342	638	463	
		3629	2328											3372	1947	3938	2487	4505	3027	5646	4098	
LRP-110	4	281	169	345	219	447	316															
		2487	1496	3053	1938	3956	2797															
	6	421	253			363	184	465	281	568	377											
		3726	2239			3213	1628	4115	2487	5027	3336											
LRP-120	8	562	337							483	245	586	342	689	439							
		4974	2982							4275	2168	5186	3027	6098	3885							
	10	702	422											604	306	707	403	810	500	1015	694	
		6213	3735											5345	2708	6257	3567	7169	4425	8983	6142	

Dimensions Size 10 to 40 (mm)

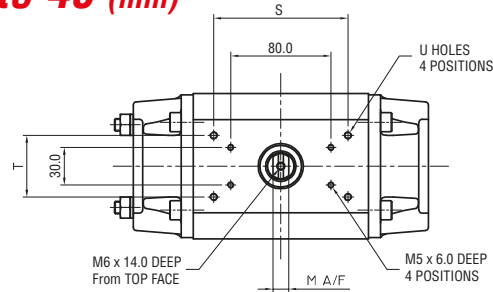

EN 15714-3 NAMUR TOP ACCESSORY MOUNTING

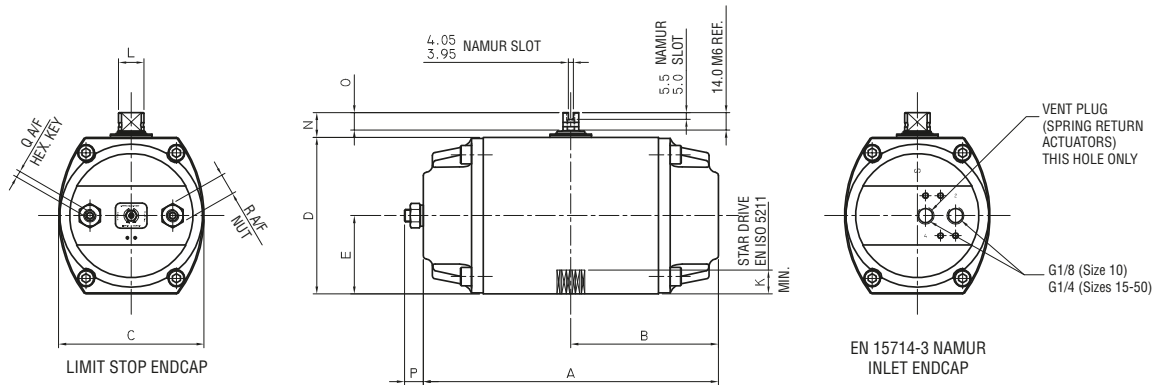

EN 15714-3 NAMUR INLET ENDCAP

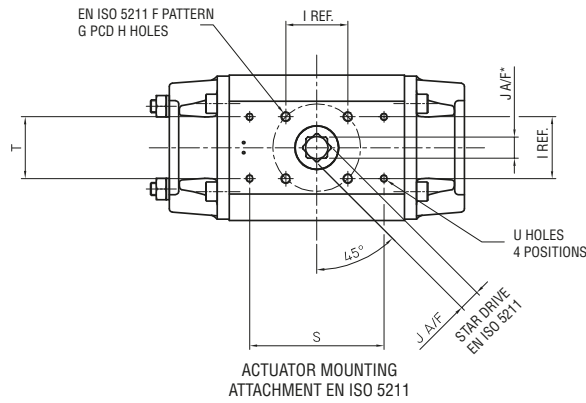

ACTUATOR MOUNTING ATTACHMENT EN ISO 5211

Size / Series	Basic Dimensions					Bottom ISO Mounting Dimensions						Top Pinion				Limit Stop			Ancillary Hole		
	A	B	C	D	E	F	G	H	I	J	K	L	M	N	O	P	Q	R	S	T	U
LRP-10	155,3	77,7	76,8	85,5	42,8	F04	42,0	M5 x 0.25 6.25 DP	29,7	11,0	12,0	15,0	9,0	20,0	16,0	10,0	4,0	13,0	73,0	31,8	M5 x 0.25 6.3 DP
LRP-15	195,3	97,7	94,0	104,0	52,0	F05	50,0	M6 x 0.30 7.5 DP	35,4	14,0	16,0	16,0	12,6	20,0	13,9	11,0	4,0	13,0	73,0	31,8	M5 x 0.24 6.0 DP
LRP-20	235,4	117,7	116,0	125,0	62,5	F07	70,0	M8 x 0.40 10.0 DP	49,5	17,0	19,0	20,3	12,6	20,0	13,8	15,0	5,0	17,0	107,2	49,2	M6 x 0.27 7.0 DP
LRP-25	271,0	135,5	135,5	146,6	73,5	F07	70,0	M8 x 0.40 10.0 DP	49,5	17,0	19,0	19,0	19,0	30,0	22,2	21,0	6,0	19,0	107,2	49,2	M6 x 0.4 10.0 DP
LRP-30	325,1	162,6	155,0	167,5	83,8	F10	102,0	M10 x 0.50 12.5 DP	72,1	22,0	24,0	22,1	22,1	30,0	21,9	23,0	6,0	19,0	161,1	73,0	M6 x 0.4 10.0 DP
LRP-33	398,7	199,4	206,0	214,0	107,0	F12	125,0	M12 x 0.70 18.0 DP	88,4	27,0	29,0	28,5	28,5	30,0	21,2	23,0	8,0	24,0	161,1	86,0	M8 x 0.5 13.0 DP
LRP-35	423,9	212,0	213,0	217,0	108,5	F12	125,0	M12 x 0.63 16.0 DP	88,4	27,0	29,0	28,5	28,5	30,0	20,9	30,0	8,0	24,0	212,7	101,6	M8 x 0.6 14.0 DP
LRP-40	511,8	255,9	244,9	276,0	149,0	F14	140,0	M16 x 0.95 24.0 DP	99,0	36,0	40,0	34,9	34,9	50,0	37,0	27,0	10,0	30,0	243,6	117,5	M10 x 0.6 15.0 DP

LRP Actuator Selection Table

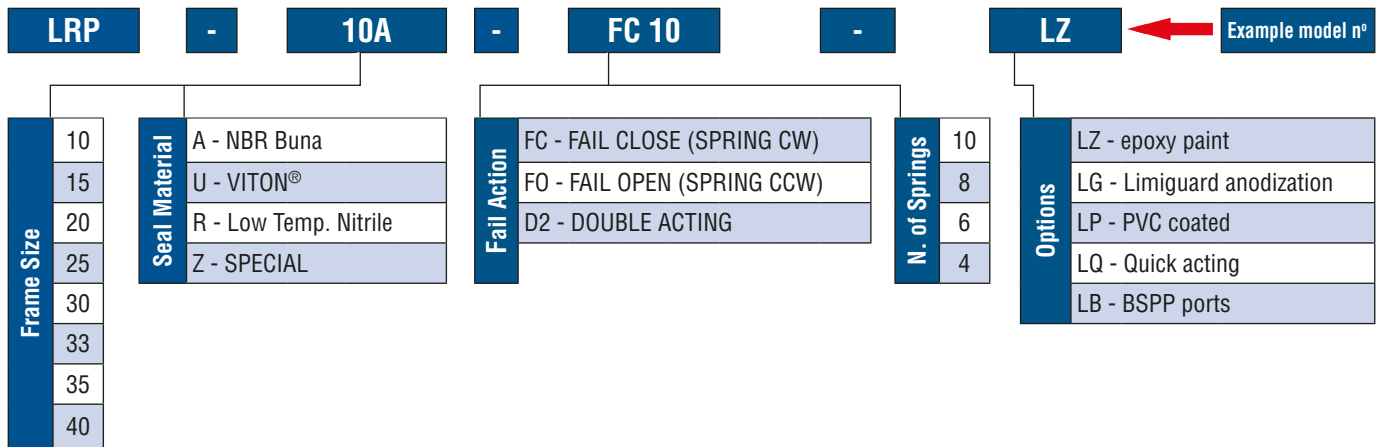

Technical Information

Size / Series	Operating Speed (Seconds) Actuator with no load using Namur solenoid at 5.5 bar (g)			Actuator Free Internal Volume Litres		Weights (Kg)	
	Double Acting	Spring Return (Open)	Spring Return (Close)	Open	Close (DA only)	Double Acting	Spring Return
LRP-10	0,15	0,15	0,15	0,17	0,22	1,3	1,6
LRP-15	0,3	0,3	0,3	0,35	0,39	2,7	3,1
LRP-20	0,5	0,5	0,5	0,69	0,74	4,5	5,5
LRP-25	0,6	0,6	0,6	1,22	1,31	7,4	8,4
LRP-30	1,1	1,4	1,0	1,86	2,05	11,0	12,0
LRP-33	2,1	2,7	1,7	3,39	4,79	22,5	26,0
LRP-35	2,9	3,2	2,2	3,93	5,54	26,0	30,0
LRP-40	3,0	4,5	3,5	6,73	8,19	43,6	48,6

Special Options

Finishes

The LRP actuator is available in a variety of special finishes to meet specific application needs. The Limiguard coating provides a special anodised finish for enhanced protection in highly corrosive or salt water atmospheres. Flowsolve also offer epoxy paint finishes and colours to customer requirements.

Fast Acting

A fast acting version can be achieved by providing direct air feed to the centre chamber and adding dump valves for air exhaust. On size 40 a large Namur solenoid mounting can be specified and mounted to the end cap.



FCD LFENBR0009-00-AQ 02/17

Contact:

For more information about Flowserve Corporation, visit www.flowserve.com or call USA 1-800-225-6989.

Italy

Flowserve Limatorque
via Rio Vallone 17
208 B 3 Mezzago (IM 18)1 Italy
Phone: +39 039 6 2060 1
Fax: +39 039 6 2060 213
Email: lfpsinfo@flowserve.com

China

Flowserve Suzhou Operations
49 Weixin Road, Suzhou
China, 215000
Phone: 86-512-62881711
Fax: 86-512-62888737

USA

Flowserve US, Inc
Valve Automation Center
14219 Westfair
West I Houston, Texas 77041
Phone: 281-671-9209
Email: VACHouston@flowserve.com

Flowserve Corporation has established industry leadership in the design and manufacture of its products. When properly selected, this Flowserve product is designed to perform its intended function safely during its useful life. However, the purchaser or user of Flowserve products should be aware that Flowserve products might be used in numerous applications under a wide variety of industrial service conditions. Although Flowserve can (and often does) provide general guidelines, it cannot provide specific data and warnings for all possible applications. The purchaser/user must therefore assume the ultimate responsibility for the proper sizing and selection, installation, operation, and maintenance of Flowserve products. The purchaser/user should read and understand the Installation Operation Maintenance (IOM) instructions included with the product, and train its employees and contractors in the safe use of Flowserve products in connection with the specific application.

While the information and specifications contained in this literature are believed to be accurate, they are supplied for informative purposes only and should not be considered certified or as a guarantee of satisfactory results by reliance thereon. Nothing contained herein is to be construed as a warranty or guarantee, express or implied, regarding any matter with respect to this product. Because Flowserve is continually improving and upgrading its product design, the specifications, dimensions and information contained herein are subject to change without notice. Should any question arise concerning these provisions, the purchaser/user should contact Flowserve Corporation at any one of its worldwide operations or offices.

© 2017 Flowserve Corporation, Irving, Texas, USA. Flowserve and Limatorque are registered trademarks of Flowserve Corporation.