



Limitorque™ LPC

Limitorque Pneumatic Compact Scotch Yoke Actuator



Experience In Motion

Limitorque Fluid Power Systems



The Flowserve Limitorque portfolio of products makes valve control easier in so many ways — in almost as many ways as the applications they serve.

The Limitorque Pneumatic Compact (LPC) range is a robust, lightweight, modular Scotch yoke design available in both spring return and double acting configurations. It is suitable for actuating ball, butterfly and plug valves or any other quarter-turn application.

LPC compact actuators deliver up to 1600 Nm* (1180 ft-lb) of precisely controlled torque. The LPC product range is complementary to the Limitorque LPS heavy-duty pneumatic Scotch yoke actuators.

A similar design philosophy to the heavy-duty LPS was applied to the new LPC range, delivering enhanced performance and high reliability. The LPC is available in standard as well as special material configurations upon request.

LPC actuators are complemented by a comprehensive range of control systems, including ESD, PST and Quick Closing options. A suite of standard controls systems is available for short delivery, but the Limitorque engineering team can design custom solutions for the largest and most complex customer requirements.

* For higher torque ranges, consult factory.

Today's industry requirements are more rigorous than ever before. Nowhere is this more evident than in the oil and gas industry where new requirements are incorporated into project specifications almost every day. Limitorque has addressed these demanding requirements in the design of their latest fluid power products, the LPC and LPS actuators. This makes LPC and LPS the most technically advanced and market-compliant actuators available anywhere in the world.

The LPC actuator features a 25-year design life, depending on service conditions, proper installation, operation and maintenance. In order to achieve this industry-leading design life, in-field maintenance is prescribed to be performed every five years of operation. For high-cycle applications, such as control valve operation, more frequent maintenance of replaceable wear surfaces, as outlined in EN 15714, may be required.

To complete the actuation package, LPC actuators are available with accessories such as lockout modules. Limitorque provides engineering design services for mounting hardware to ensure that your actuation solution is ready to handle the toughest challenges.



LPC Limatorque Pneumatic Compact Scotch Yoke Actuators

With a 25-year design life* and a maintenance interval up to five years*, the LPC Limatorque Pneumatic Compact actuator is a complementary product to the available range of Limatorque LPS heavy-duty pneumatic Scotch yoke actuators.

Features

- Spring Return Single Acting (Fail Close CW and Fail Open CCW) and Double Acting (Fail Last / Fail-as-is) executions
- Easy field conversion from Fail Close CW to Fail Open CCW configuration or vice versa
- Symmetrical and Canted Scotch yoke types to perfectly fit valve torque requirement
- Housing constructed in Nodular Ductile Cast Iron or Carbon Steel; different materials of construction upon request
- Carbon Steel ENP lined Cylinders; Stainless Steel Cylinders, Tie Rods and Spool Pieces available upon request
- Upon request, available in balanced weight configuration, with cylinder and spring installed on opposite sides of central body**
- Available for use in safety integrated systems up to and including SIL Level 3 in accordance with IEC 61508
- Suitable for use in on/off, modulating and control valve application in general service, protective service and safety applications such as ESD or HIPPS
- Full range of accessories: switchboxes, positioners; ESD and PST functionalities; custom control panels; fire protection; manual and hydraulic overrides

Specifications

- Torque range up to 1600 Nm (1180 ft-lb)**
- Maximum allowable working pressure (MAWP): 12 barg (174 PSIG)
- -29°C to 100°C (-20°F to 212°F) standard operating temperature range; Low temperature -60°C (-76°F) and high temperature 160°C (320°F) ranges available upon request (polar, cold, arid and tropical temperature requirements in accordance with IEC 60721)
- End mounted adjustable travel stop $\pm 5^\circ$, available also in an enclosed protected version upon request

Key Certifications and Standards Compliance

- Certified according to ATEX 94/9/EC Ex II 2GD c IIC T6
- NEMA4 and NEMA4X per NEMA 250
- IP66/IP66M and IP67/IP67M configurations
- Available valve interface in compliance with ISO 5211
- Actuator spring design in compliance with EN 13906
- Corrosion protection in compliance with ISO 12944-2 and EN 15714-3; optionally available up to and including C5-M
- Available in compliance with NACE specification MR0175 for sour gas applications
- Available in compliance with PED 97/23/EC, ASME BPVC Sec. VIII Div. 1, EN 13445-3 Part 2 for Unfired Pressure Vessels
- Manufactured and tested in compliance with ISO 9001 and EN 15714-3

* Depending on service conditions, proper installation, operation and maintenance.

** Consult factory for other sizes or for more information.

LPC Modular Design and Accessories



LPC Spring Return Without Manual Override



LPC Spring Return With Manual Override



LPC Double Acting Without Manual Override



LPC Double Acting With Manual Override



LPC Special (Balanced Weight) Configuration, With Cylinder and Spring Installed on Opposite Sides of Central Body

Anatomy of Limitorque LPC Actuator

The LPC range of Limitorque Pneumatic Actuators is a robust, lightweight modular Scotch yoke design, available in both spring return and double acting configurations. The LPC product range is complementary to the already available range of Limitorque LPS heavy-duty pneumatic Scotch yoke actuators. A similar design philosophy to the heavy-duty LPS was applied to the new LPC range, delivering enhanced performance and high reliability. The LPC is available in a selection of standard as well as special materials, upon request.

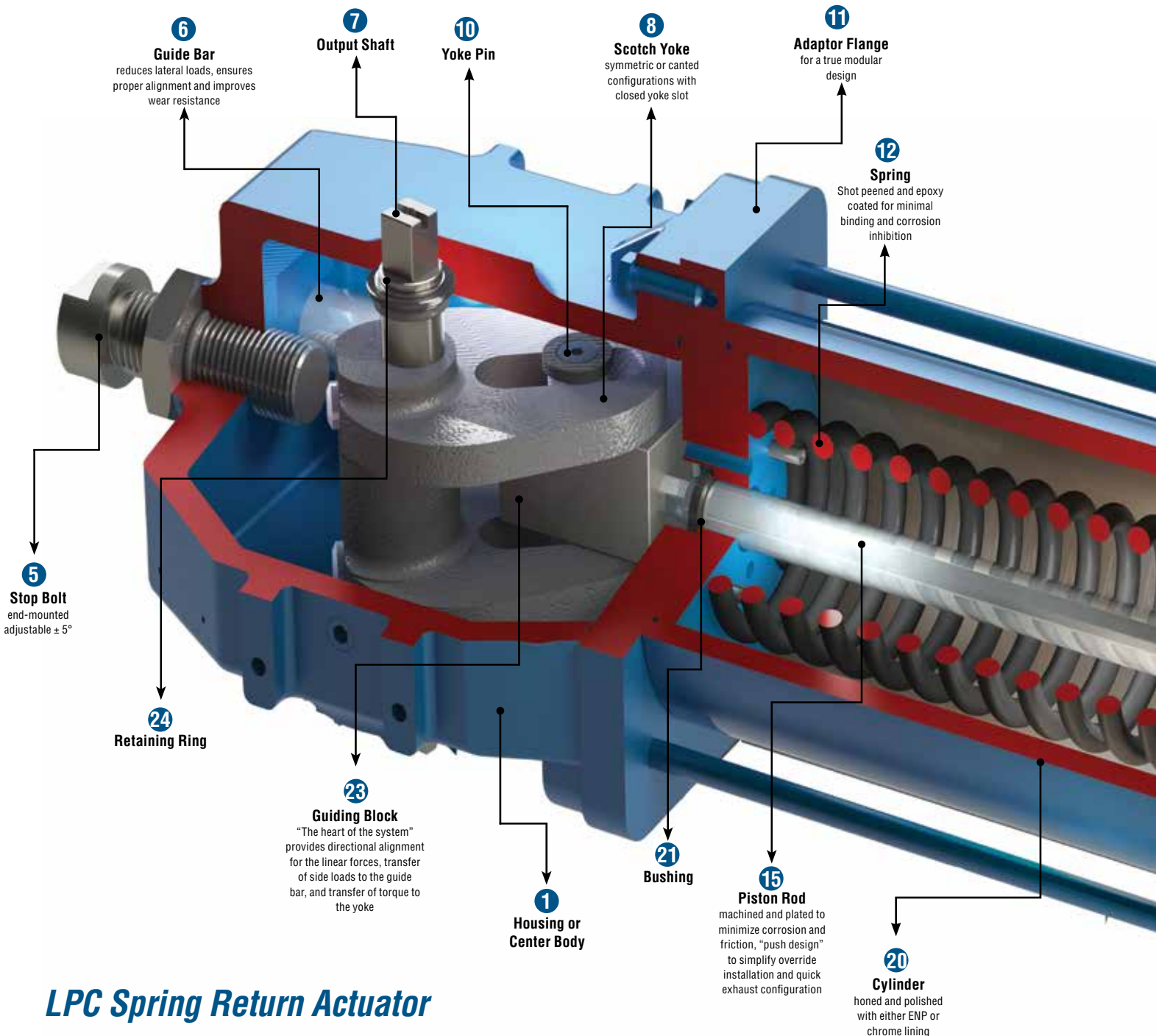

LPC Spring Return Actuator

LPC Double Acting Actuator

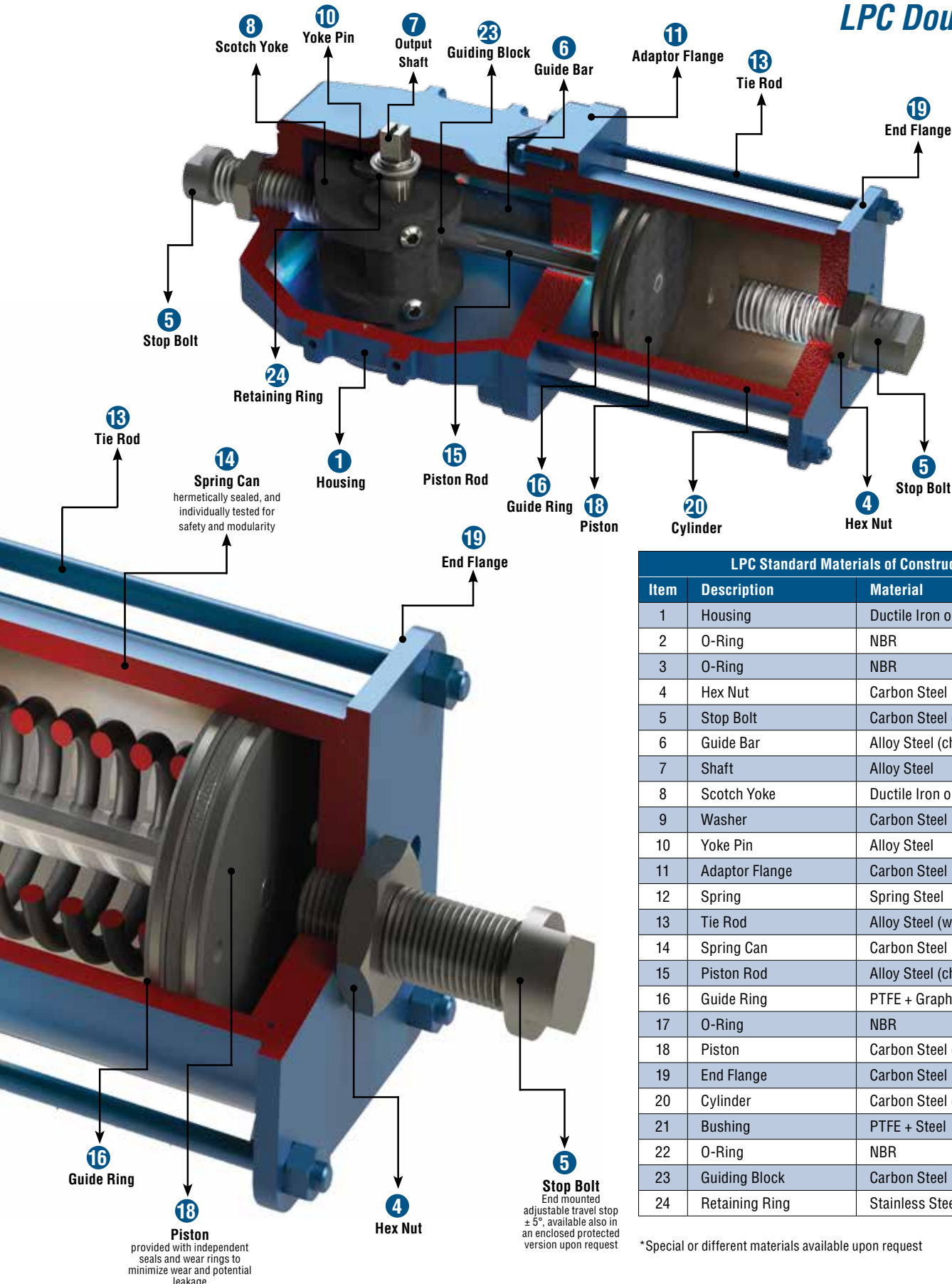

LPC Standard Materials of Construction		
Item	Description	Material
1	Housing	Ductile Iron or Carbon Steel
2	O-Ring	NBR
3	O-Ring	NBR
4	Hex Nut	Carbon Steel
5	Stop Bolt	Carbon Steel (with treatment)
6	Guide Bar	Alloy Steel (chrome plated)
7	Shaft	Alloy Steel
8	Scotch Yoke	Ductile Iron or Carbon Steel
9	Washer	Carbon Steel
10	Yoke Pin	Alloy Steel
11	Adaptor Flange	Carbon Steel
12	Spring	Spring Steel
13	Tie Rod	Alloy Steel (with treatment)
14	Spring Can	Carbon Steel
15	Piston Rod	Alloy Steel (chrome plated)
16	Guide Ring	PTFE + Graphite
17	O-Ring	NBR
18	Piston	Carbon Steel (with treatment)
19	End Flange	Carbon Steel
20	Cylinder	Carbon Steel (with treatment)
21	Bushing	PTFE + Steel
22	O-Ring	NBR
23	Guiding Block	Carbon Steel
24	Retaining Ring	Stainless Steel

18 Piston
provided with independent seals and wear rings to minimize wear and potential leakage

5 Stop Bolt
End mounted adjustable travel stop $\pm 5^\circ$, available also in an enclosed protected version upon request

*Special or different materials available upon request

LPC Actuator Selection Table

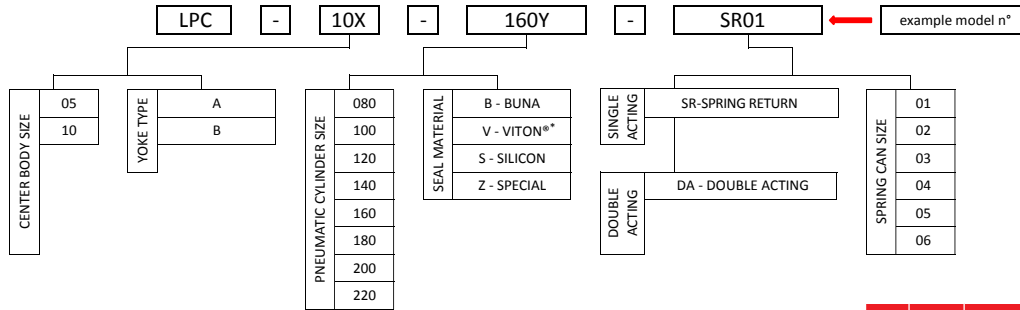

Seals Material

Code	Material	Temperature Range	Climate Classification according to IEC60721
B	Buna	Std Temp: -29°C to +100°C (-20°F to 212°F)	Tropical & Arid
V	Viton®	Hi Temp: up to +160°C (320°F)	
S	Silicon	Low Temp: down to -40°C (-40°F)	Temperate
Z	Other	Special Applications - Consult Factory	Cold & Polar

LPC Torque and Pressure Table

Model	MOT Maximum Operating Torque Nm (ft-lb)	MOP Maximum Operating Pressure barg (PSIG)	MAWP Maximum Allowable Working Pressure barg (PSIG)
LPC-05	500 (369)	Variable for every cylinder size. Please refer to Technical Bulletin LFENTB0002.	12 (174)
LPC-10	1600 (1180)*		

* For higher output torques, consult factory.

LPC Sizing and Selection

Due to the Scotch yoke mechanism, LPC actuators have a particular U-shaped output torque curve, whether powered by a fixed supply pressure or the spring.

For a proper actuator model selection, the safety factors between actuator output torque and valve torque requirement shall be calculated at least in six points along the valve stroke. In addition, a final check is necessary to guarantee that actuator Maximum Output Torque does not exceed valve Maximum Allowable Stem Torque (MAST).

The minimum set of parameters and features necessary for an optimal actuator selection:

- Valve torques, including MAST
- Type of actuator:
 - Single Acting/Spring Return: Fail Safe Close (CW) or Fail Safe Open (CCW)
 - Double Acting configuration for Fail Last or Fail As Is
- Minimum, Normal and Maximum Pneumatic Supply pressure to the actuator
- Safety Factors requested by the project or by a specific application
- Working Temperature range
- Open/Close stroking times
- Additional options (manual override, control panel, limit switch box, positioner,...)

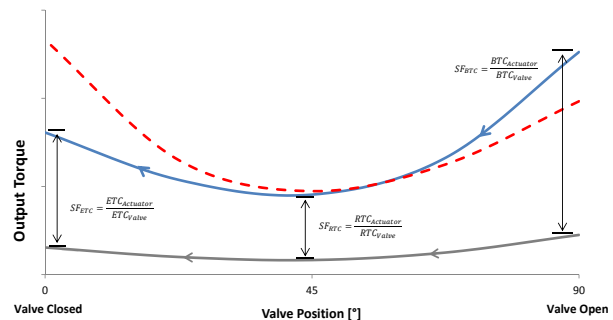
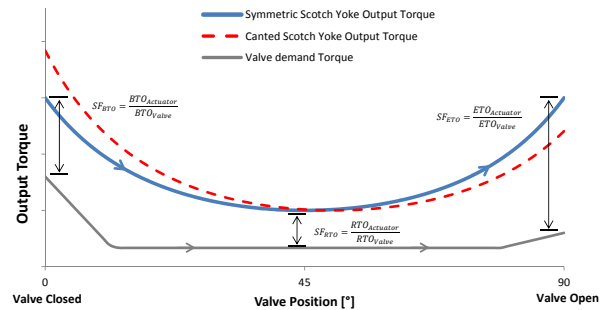

Detailed output torque graphs covering the full valve stroke are available for both spring return and double acting actuators.

Definitions

BTO	Break to open torque	BTC	Break to close torque
RTO	Running to open torque	RTC	Running to close torque
ETO	End to open torque	ETC	End to close torque
MAST	Maximum allowable stem torque	SF	Safety factor

*Viton is a registered trademarks of E. I. du Pont de Nemours

Control System Options

Limatorque offers a selection of standard and custom controls packages for most applications to fill customers' needs for short lead-time, low-cost solutions.

- PST
- ESD
- Quick-closing
- Modulating/CV functionality
- Quick exhaust valve with flow regulator suitable for closed loop assembly, when required
- Cylinder integral quick exhaust valve (double acting fast actuator)
- Pneumatic booster (¼ in, ½ in, 1 in size, AL and 316 SS)
- 3/2 and 5/2 pneumatic piloted valve with manual reset and override (¼ in, ½ in, 1 in size, AL and 316 SS)
- Unidirectional and bidirectional flow regulator valve (¼ in, ½ in, 1 in size, AL and 316 SS)
- Compact fittings to reduce pipe and control dimensions (¼ in, ½ in, 1 in size, AL and 316 SS)

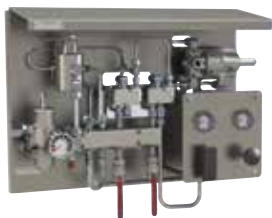

Flowserve Solutions

In addition to providing actuators and controls designed to meet or exceed all of today's rigorous requirements, Flowserve and Limatorque lead the industry with all of the essential related solutions that our customers need to maintain peak efficiency and productivity.

- Aftermarket Parts and Services
- Business Assessments
- Actuator Inspection, Maintenance and Repair
- Engineering and Technical Services
 - Engineering Support
 - Technical Assessments
 - Equipment Performance Analysis and Upgrades
- Education and Training
 - On-site Training
 - Online Training
- Asset Data Management and Optimization Solutions

Limatorque Additional Product Range Offering

Electric Actuators and Controls

- MX — Non-intrusive, electronic multi-turn actuators
- QX — Non-intrusive, electronic quarter-turn actuators
- Master station, controller for redundant networked actuators
- Network controls, Modbus, Profibus DP/PA, Foundation Fieldbus, DeviceNet, HART
- L120 — Electro-mechanical, multi-turn electric actuators with integral and network controls
- SMB — Electro-mechanical, multi-turn electric actuators for nuclear and severe duty service

Fluid Power Actuators

- Scotch yoke pneumatic actuators — LPS
- Compact Scotch yoke pneumatic actuators — LPC
- Scotch yoke hydraulic actuators — LHS
- Compact Scotch yoke hydraulic actuators — LHC*
- Linear pneumatic actuators — LPL
- Linear hydraulic actuators — LHL
- Direct gas actuators — LDG*
- Gas over oil actuators — LGO*
- Electro-hydraulic actuators — LEH*
- Standard and customized controls
- Application engineering support

Gearboxes

- V — Bevel gearboxes for manual or motorized operation
- WG — Worm gearboxes for manual or motorized operation
- SR — Spur gearboxes for manual or motorized operation

One Flowserve Solution

Flowserve brands for most common control accessories:

- | | |
|-----------------------|-----------------------|
| • Digital Positioners | • Valve Controllers |
| – Logix™ | – Automax™ |
| – PMV™ | – Worcester Controls™ |
| • Analog Positioners | • Limit Switch Boxes |
| – PMV | – Worcester Controls |
| – Accord™ | – PMV |
| • Diagnostic Software | – Automax |
| – ValveSight™ | – Accord |

*Contact Flowserve for product availability and additional information.



Limitorque™ LPC

Limitorque Pneumatic Compact Scotch Yoke Actuator



Experience In Motion